

## Performance of Multimedia Delivery on the Internet Today

*Kevin Jeffay*

Department of Computer Science  
University of North Carolina at Chapel Hill

*jeffay@cs.unc.edu*

November 9, 1999

<http://www.cs.unc.edu/~jeffay/courses/comp249f99>

1

## Performance on the Internet Today

### Outline

---

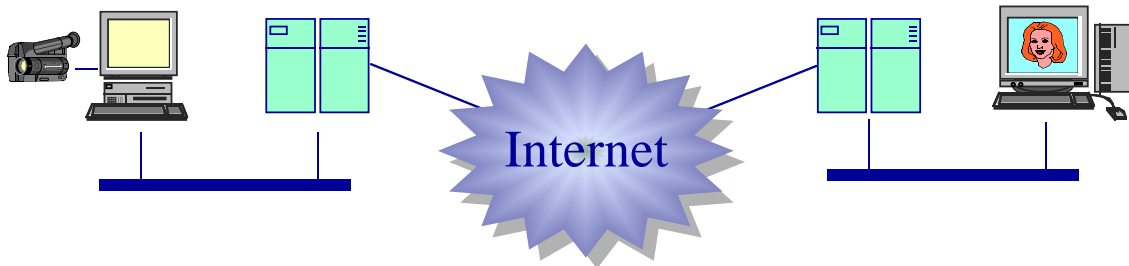

- ◆ A prototypical videoconferencing system
  - » Architecture
  - » Quality-of-service requirements
- ◆ Performance metrics
  - » Understanding end-to-end latency
- ◆ Some typical experimental results
- ◆ Conclusions?

2

# Performance on the Internet Today

## Videoconferencing performance requirements

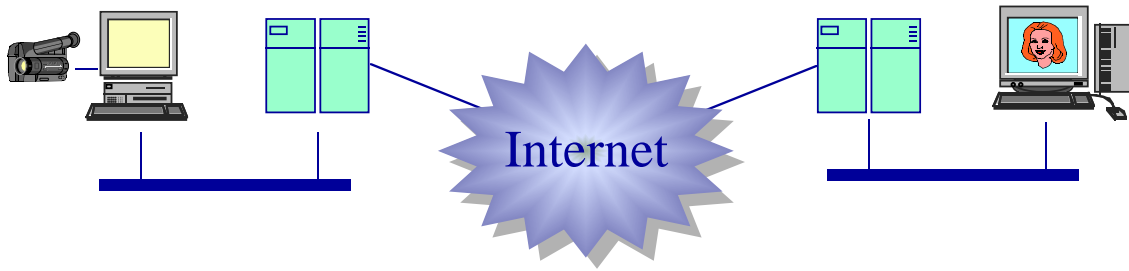

- ◆ No more than 250 ms end-to-end, one-way latency
- ◆ Continuous audio
- ◆ Minimum of 10 frames per second video throughput
- ◆ “Loosely synchronized” playout —  $\pm 80$  ms skew

3

## Videoconferencing Performance Requirements

### Understanding end-to-end latency

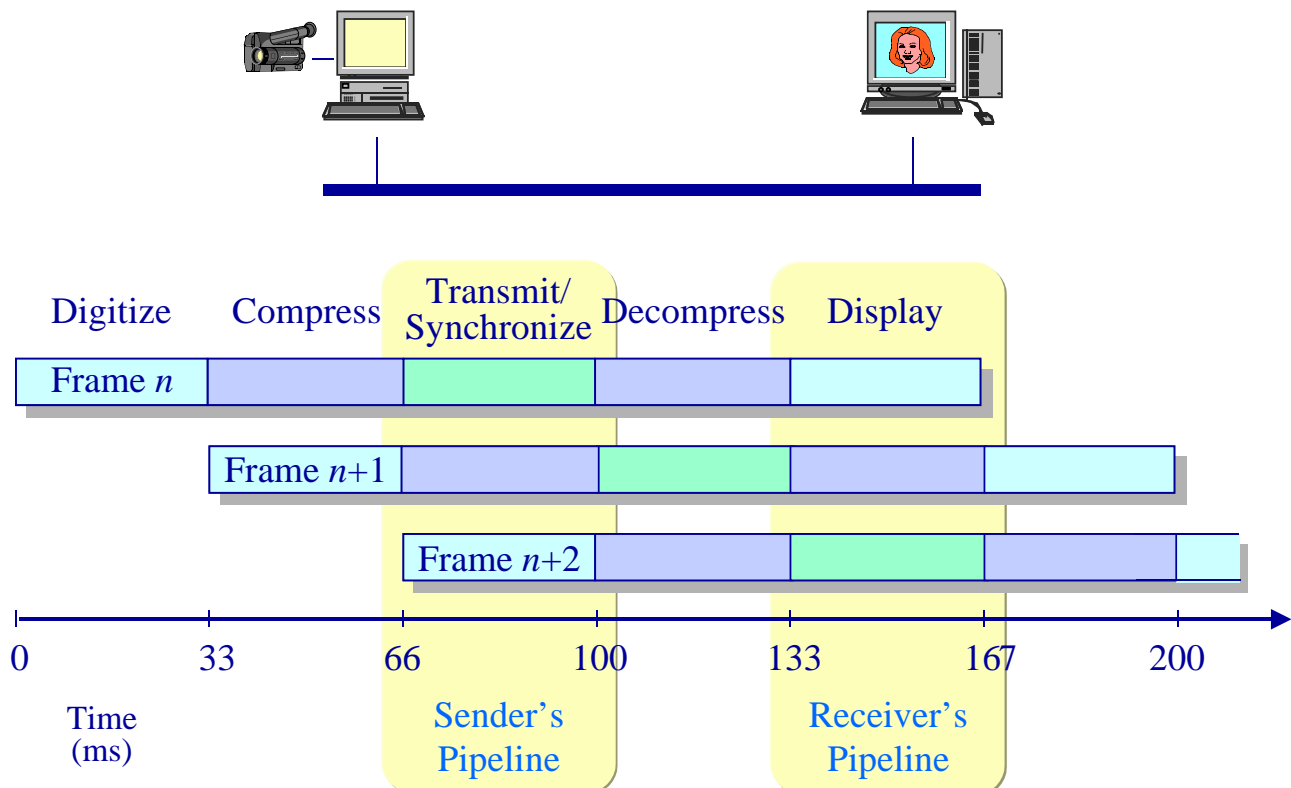

4

# Understanding End-to-End Latency

## Latency as a measure of continuity of playout

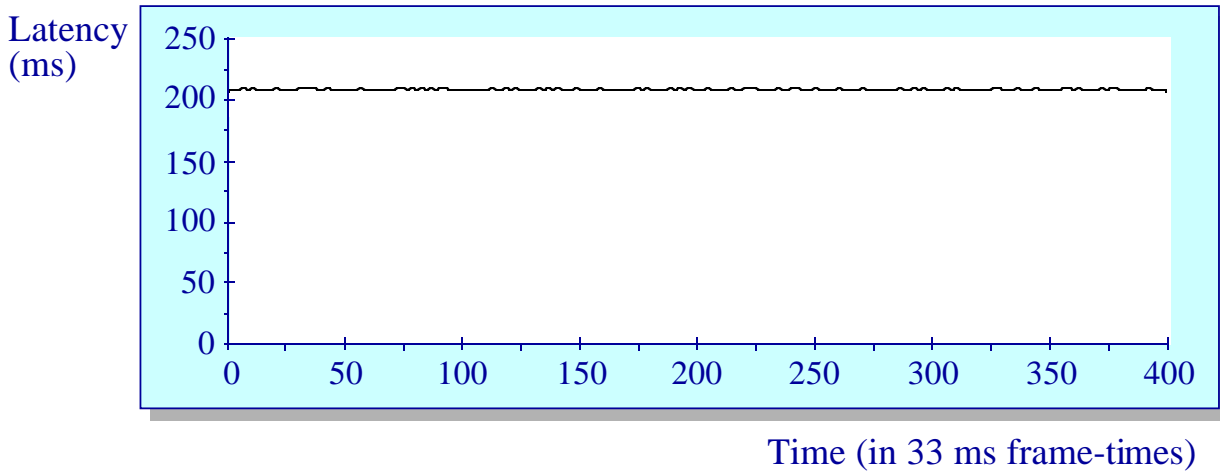
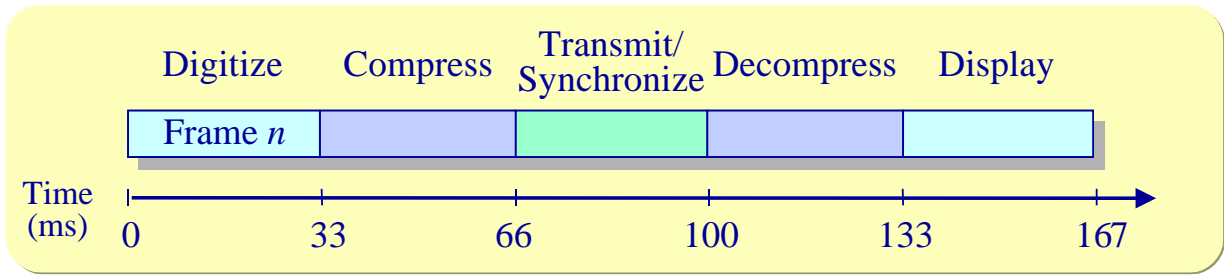

5

# Understanding End-to-End Latency

## Latency as a measure of continuity of playout

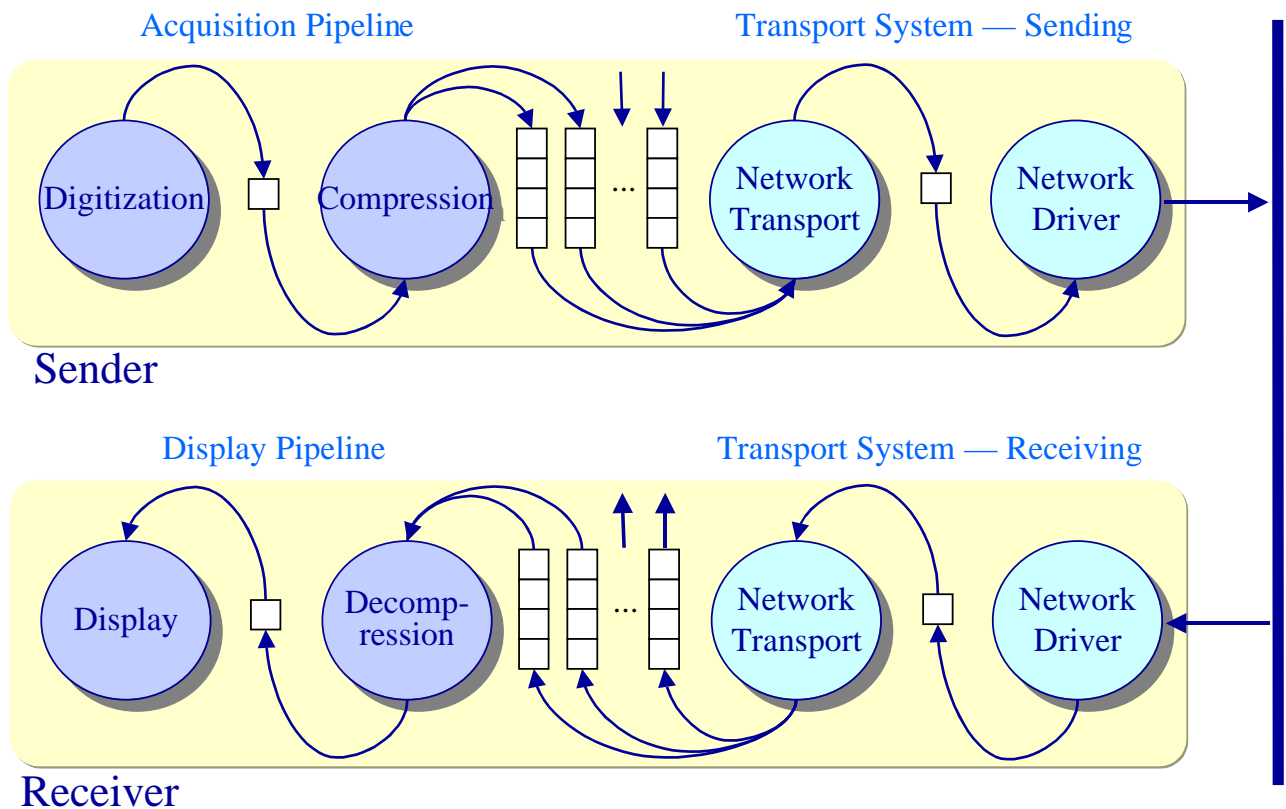

6

# Understanding End-to-End Latency

## Latency as a measure of continuity of playout

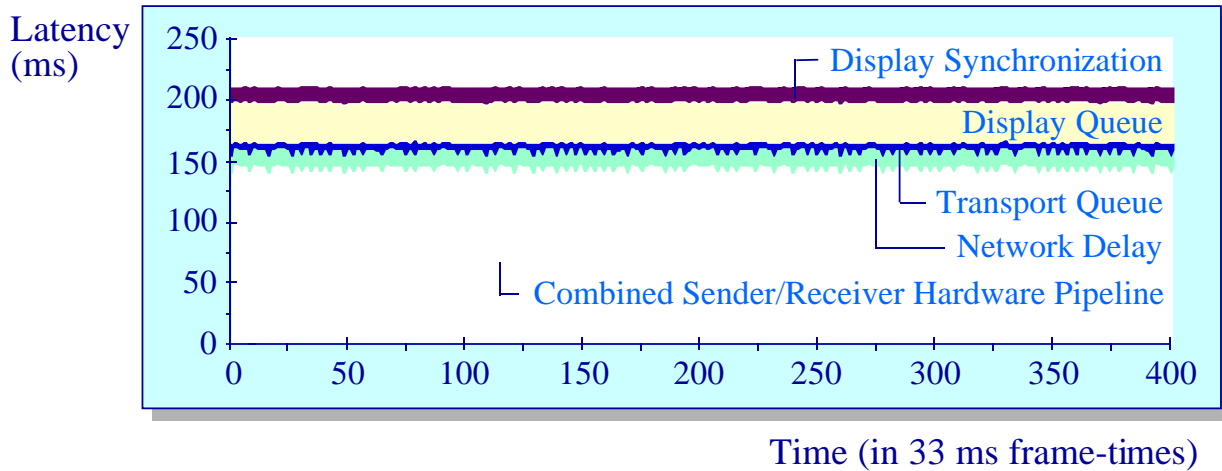
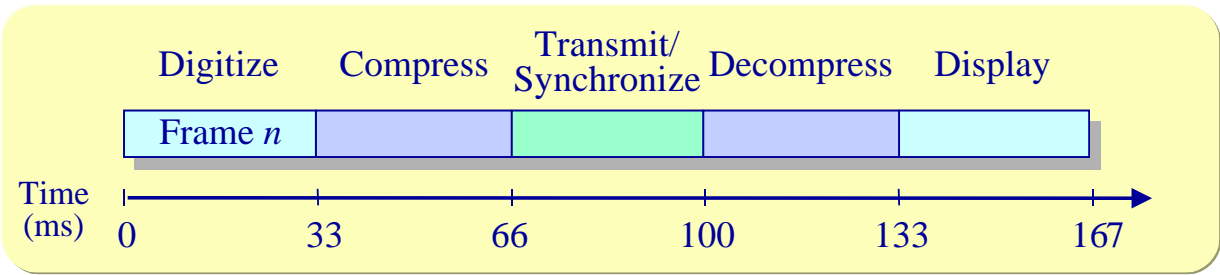

7

# Understanding End-to-End Latency

## Audio performance

- ◆ To provide lip synchronization, audio must be delayed to “wait” for video

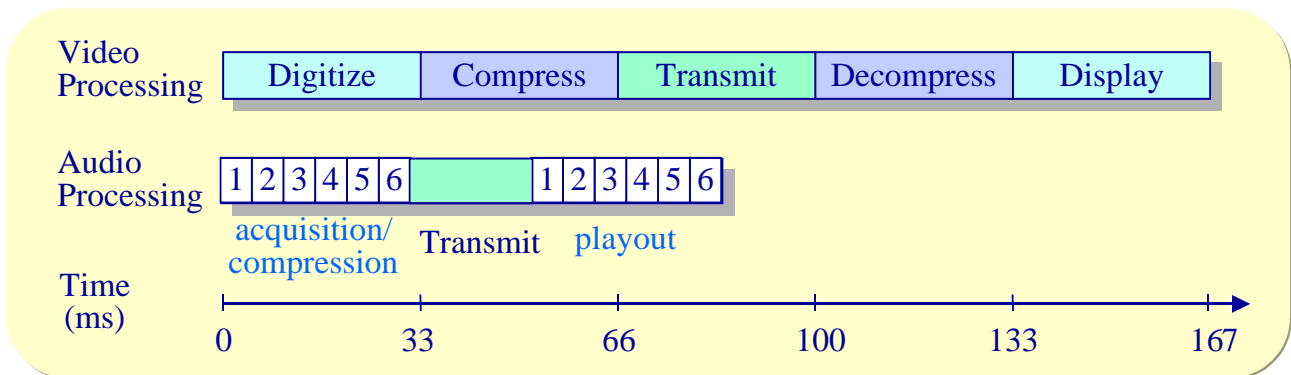

8

# Understanding End-to-End Latency

## Latency as a measure of lip synchronization

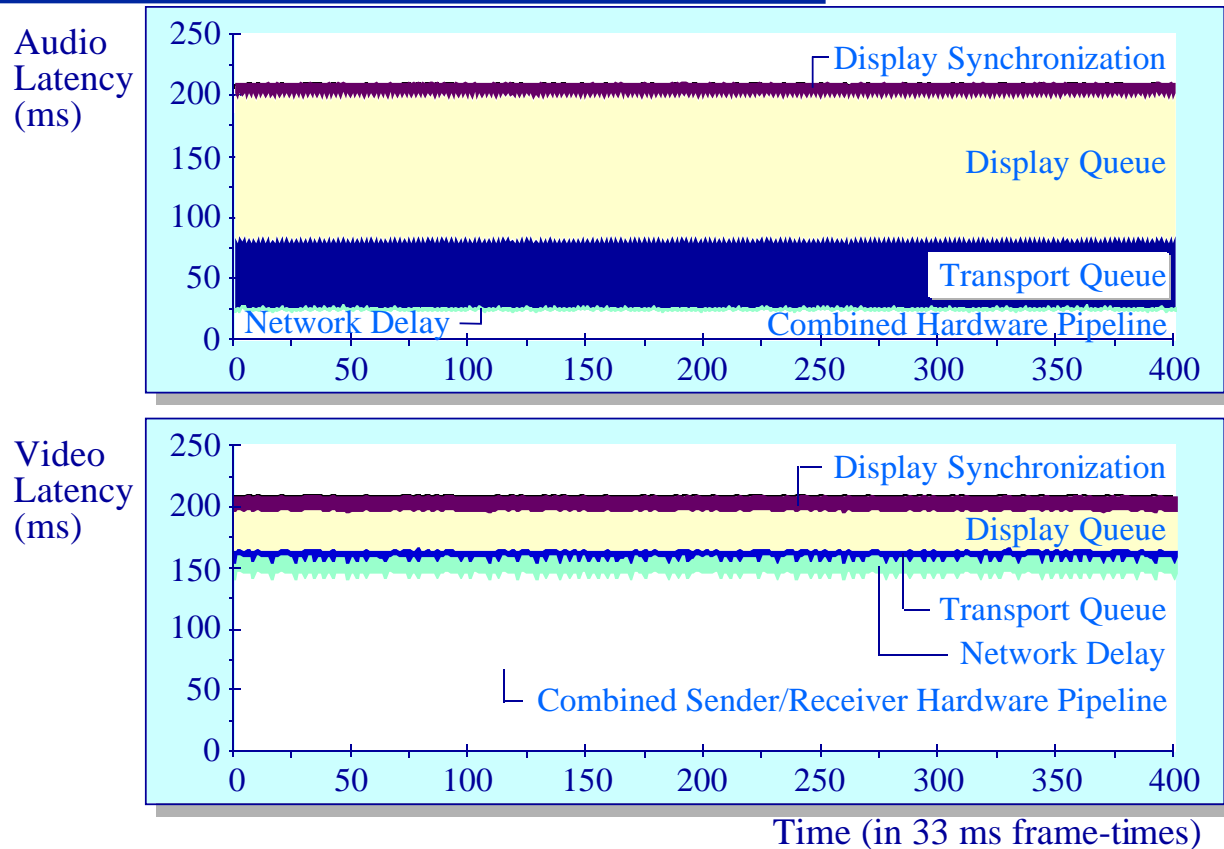

9

# Understanding End-to-End Latency

## Latency as a measure of delay-jitter

- ◆ Delay-jitter increases playout latency

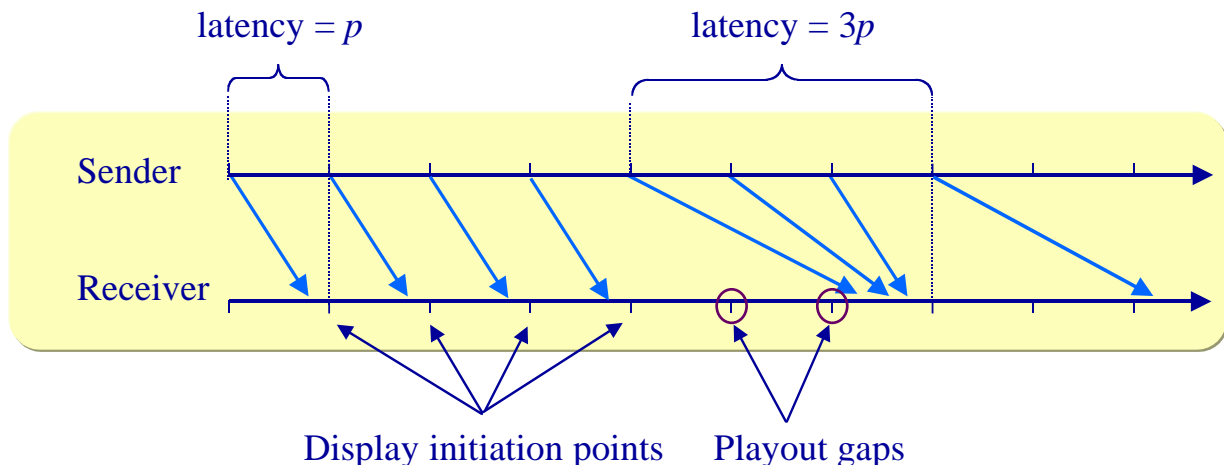

10

# Understanding End-to-End Latency

## Latency as a measure of delay-jitter

- ◆ Recall that actual playout time is not a function of the arrival time, only of the end-to-end delay
  - » The key application decision is how long to delay the initial sample prior to playout

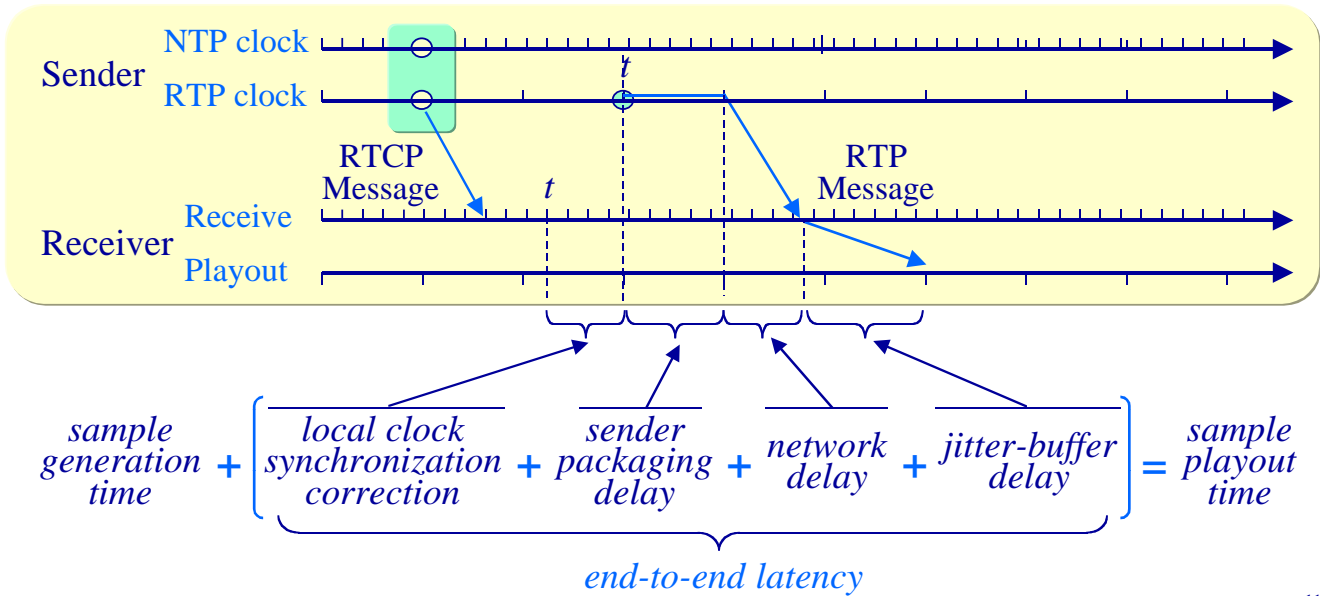

11

# Understanding End-to-End Latency

## Latency as a measure of delay-jitter

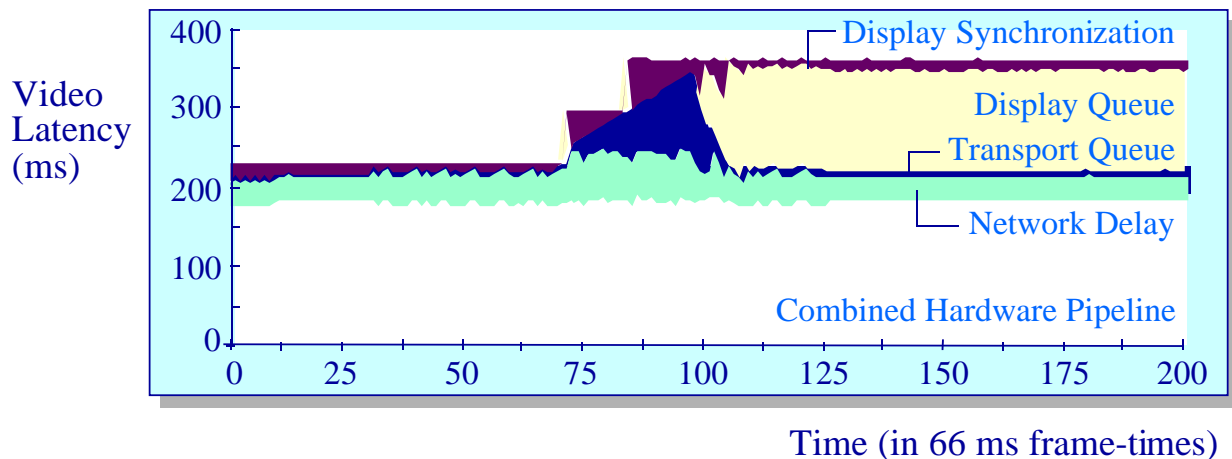
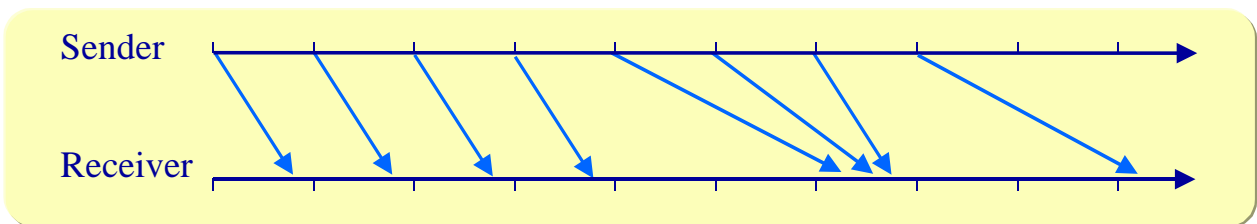

12

# Understanding End-to-End Latency

## Network v. application latency

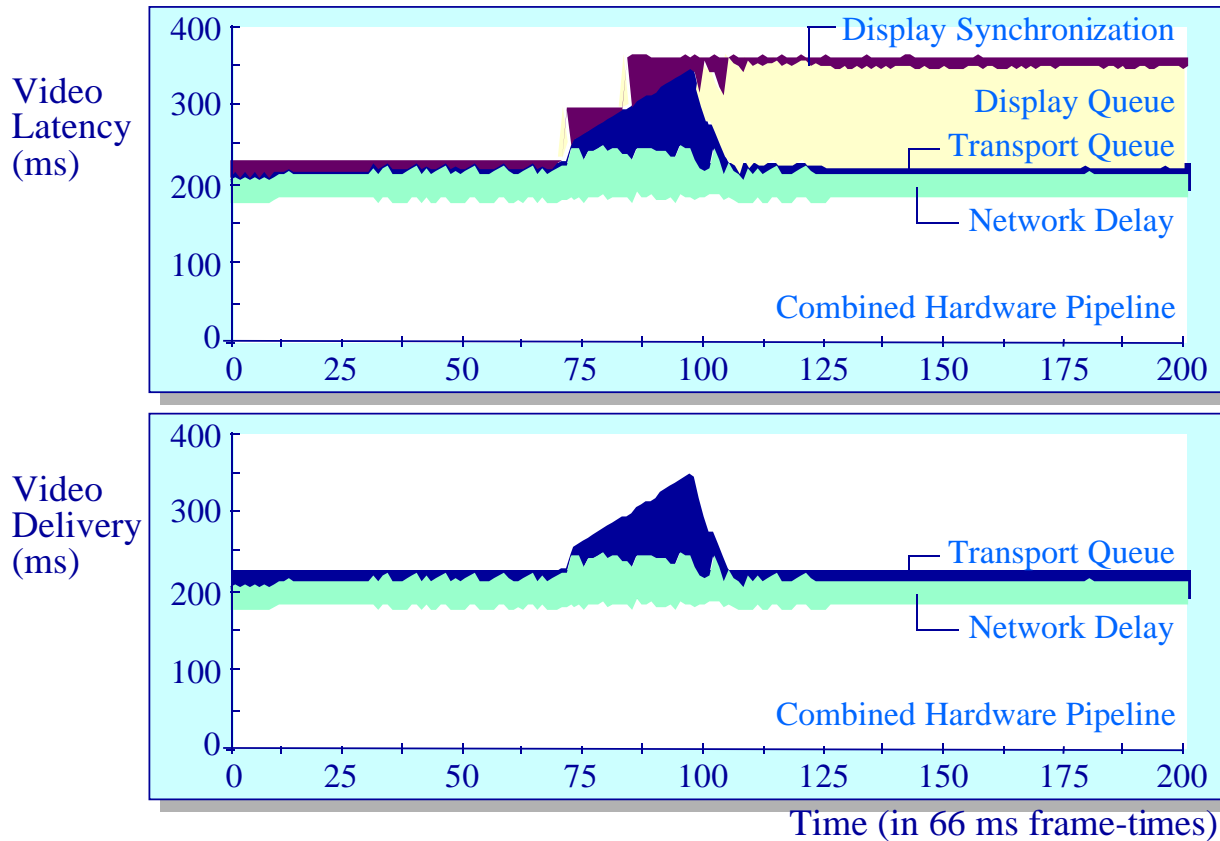

13

## Network v. Application Latency

### Is application induced latency bad?

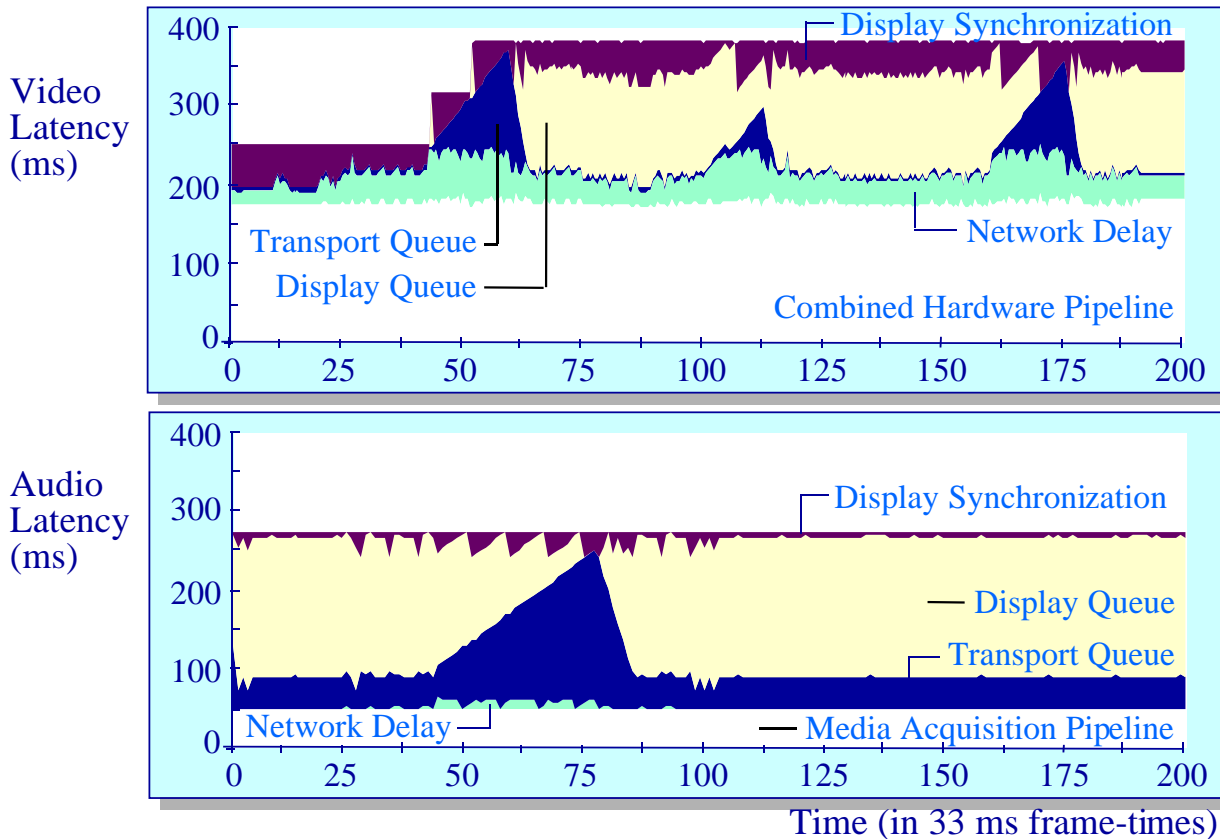

14

# Videoconferencing on the Internet Today

## ProShare™ performance on the Internet

Throughput (frames/sec)

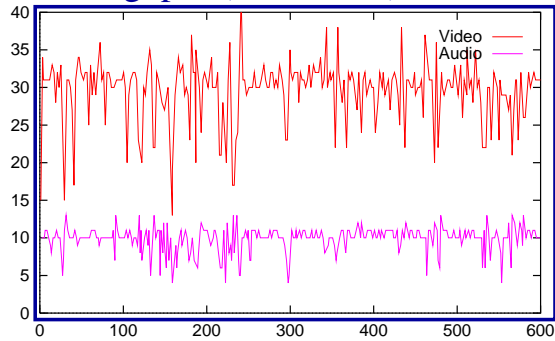

Audio Latency (ms)

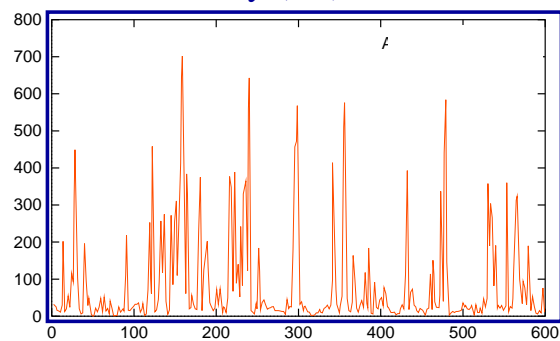

Packet Loss

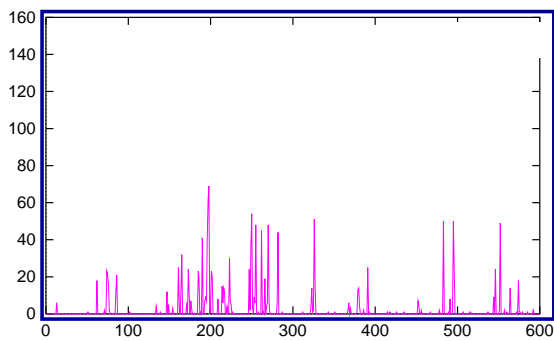

Video Latency (ms)

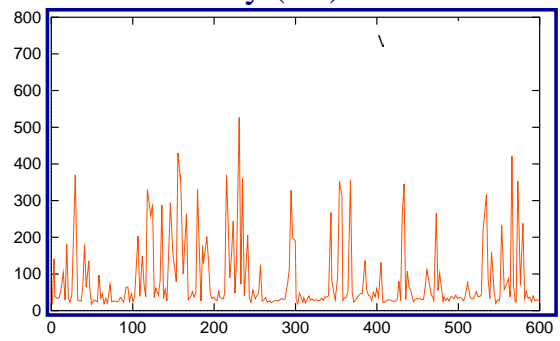

15

# Videoconferencing on the Internet Today

## ProShare™ performance on the Internet

Throughput (frames/sec)

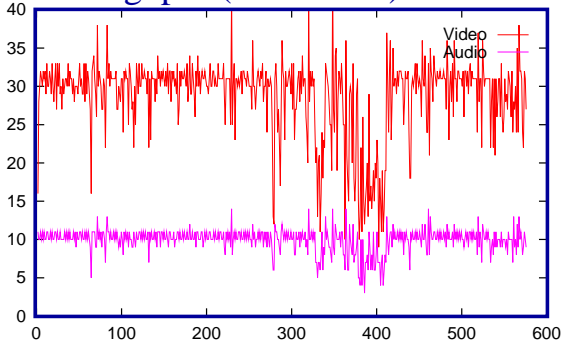

Audio Latency (ms)

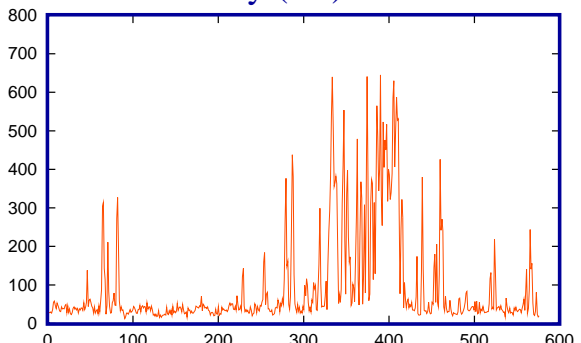

Packet Loss

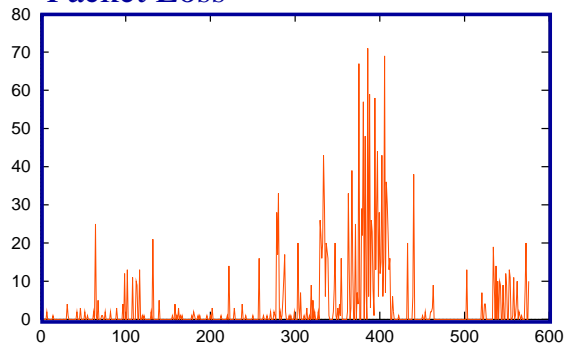

Video Latency (ms)

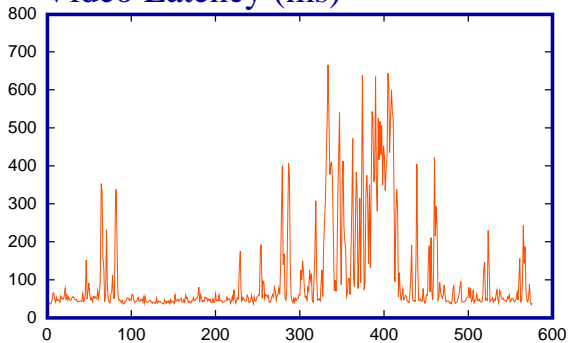

16

# Videoconferencing on the Internet Today

## What's the problem?

- ◆ Where is data being delayed and lost?

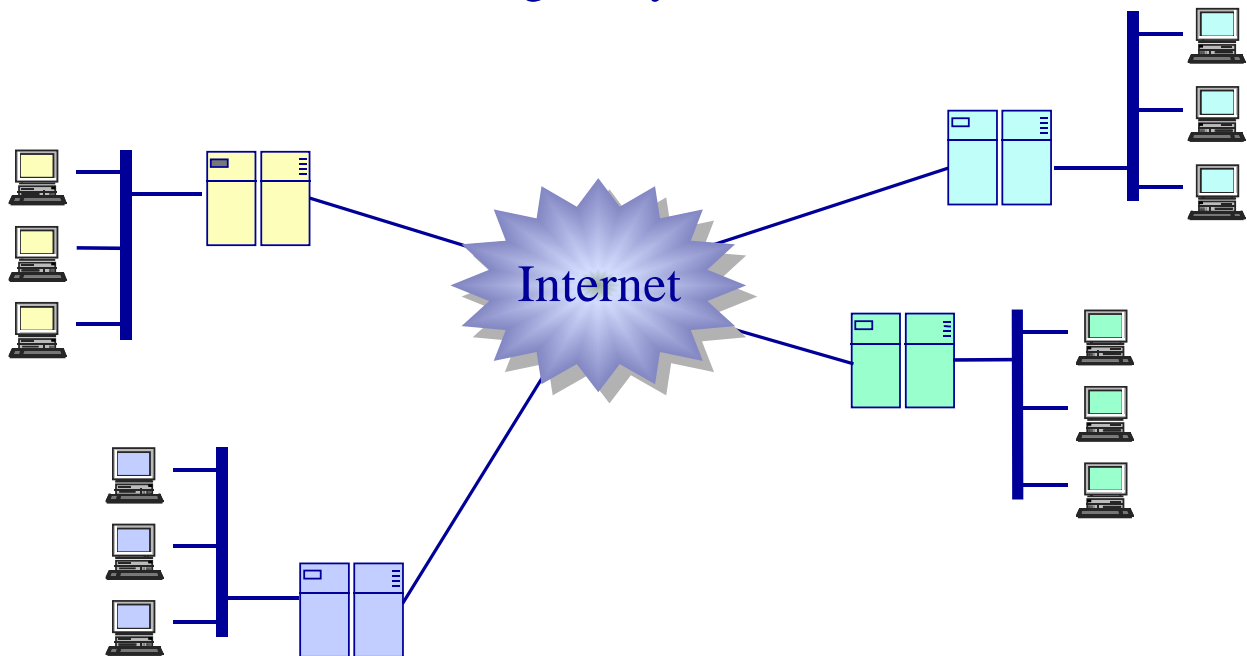

17

# Videoconferencing on the Internet Today

## What's the problem?

- ◆ Do we need more bandwidth or just better management of the existing bandwidth?

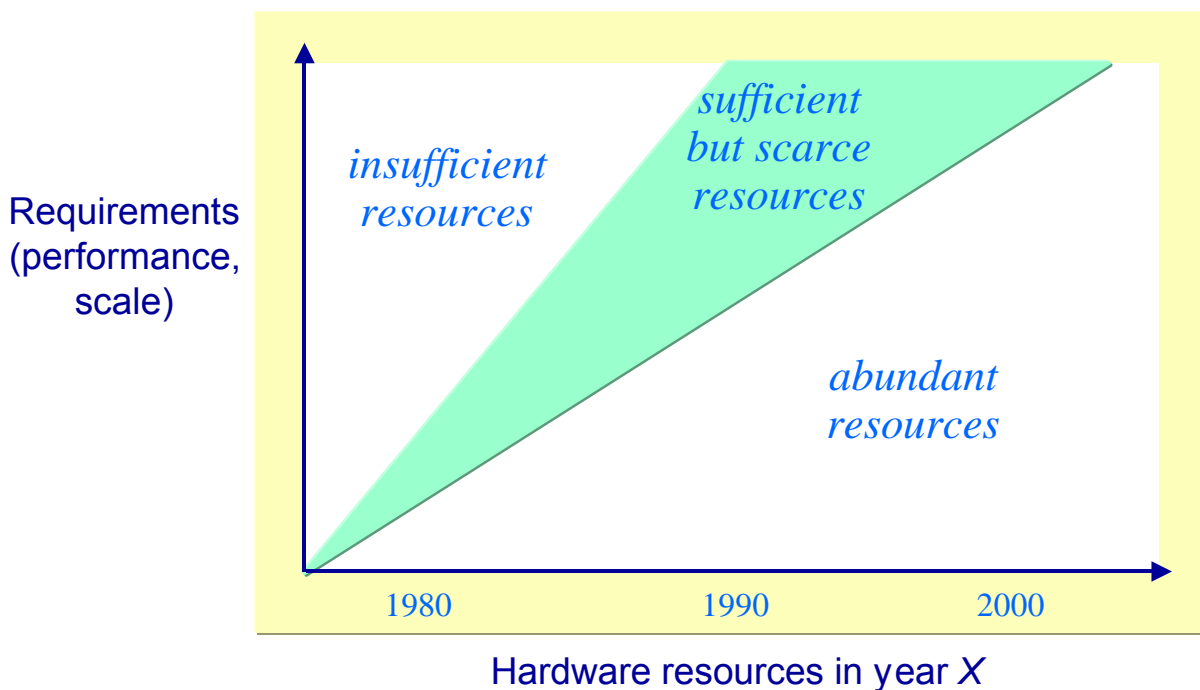

18

# Where do we go from here?

## Two fundamental approaches

---

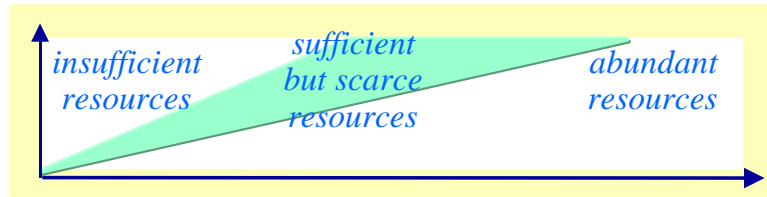

- ◆ Provide true quality-of-service through reservation of resources in the network
  - » Requires coordination amongst all parties
    - ❖ admission control
    - ❖ policing
    - ❖ ...
- ◆ Provide “best-effort” service by adapting media streams
  - » Monitor & provide feedback on performance
  - » Bias transmission and processing of media to ameliorate the effects of congestion