

NASA/TM-2001-211251

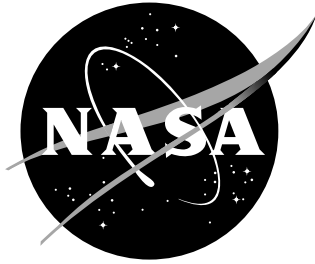

Structural Damage Detection Using Virtual Passive Controllers

Jiann-Shiun Lew
Tennessee State University, Nashville, Tennessee

Jer-Nan Juang
Langley Research Center, Hampton, Virginia

December 2001

The NASA STI Program Office ... in Profile

Since its founding, NASA has been dedicated to the advancement of aeronautics and space science. The NASA Scientific and Technical Information (STI) Program Office plays a key part in helping NASA maintain this important role.

The NASA STI Program Office is operated by Langley Research Center, the lead center for NASA's scientific and technical information. The NASA STI Program Office provides access to the NASA STI Database, the largest collection of aeronautical and space science STI in the world. The Program Office is also NASA's institutional mechanism for disseminating the results of its research and development activities. These results are published by NASA in the NASA STI Report Series, which includes the following report types:

- **TECHNICAL PUBLICATION.** Reports of completed research or a major significant phase of research that present the results of NASA programs and include extensive data or theoretical analysis. Includes compilations of significant scientific and technical data and information deemed to be of continuing reference value. NASA counterpart of peer-reviewed formal professional papers, but having less stringent limitations on manuscript length and extent of graphic presentations.
- **TECHNICAL MEMORANDUM.** Scientific and technical findings that are preliminary or of specialized interest, e.g., quick release reports, working papers, and bibliographies that contain minimal annotation. Does not contain extensive analysis.
- **CONTRACTOR REPORT.** Scientific and technical findings by NASA-sponsored contractors and grantees.

- **CONFERENCE PUBLICATION.** Collected papers from scientific and technical conferences, symposia, seminars, or other meetings sponsored or co-sponsored by NASA.
- **SPECIAL PUBLICATION.** Scientific, technical, or historical information from NASA programs, projects, and missions, often concerned with subjects having substantial public interest.
- **TECHNICAL TRANSLATION.** English-language translations of foreign scientific and technical material pertinent to NASA's mission.

Specialized services that complement the STI Program Office's diverse offerings include creating custom thesauri, building customized databases, organizing and publishing research results ... even providing videos.

For more information about the NASA STI Program Office, see the following:

- Access the NASA STI Program Home Page at <http://www.sti.nasa.gov>
- E-mail your question via the Internet to help@sti.nasa.gov
- Fax your question to the NASA STI Help Desk at (301) 621-0134
- Phone the NASA STI Help Desk at (301) 621-0390
- Write to:
NASA STI Help Desk
NASA Center for AeroSpace Information
7121 Standard Drive
Hanover, MD 21076-1320

NASA/TM-2001-211251

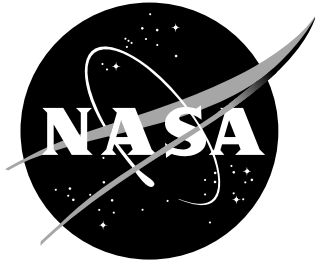

Structural Damage Detection Using Virtual Passive Controllers

Jiann-Shiun Lew
Tennessee State University, Nashville, Tennessee

Jer-Nan Juang
Langley Research Center, Hampton, Virginia

National Aeronautics and
Space Administration

Langley Research Center
Hampton, Virginia 23681-2199

December 2001

Available from:

NASA Center for AeroSpace Information (CASI)
7121 Standard Drive
Hanover, MD 21076-1320
(301) 621-0390

National Technical Information Service (NTIS)
5285 Port Royal Road
Springfield, VA 22161-2171
(703) 605-6000

STRUCTURAL DAMAGE DETECTION USING VIRTUAL PASSIVE CONTROLLERS

Jiann-Shiun Lew*

Tennessee State University, Nashville, TN 37203

Jer-Nan Juang †

NASA Langley Research Center, Hampton, VA 23681

Abstract

This paper presents novel approaches for structural damage detection which uses the virtual passive controllers attached to structures, where passive controllers are energy dissipative devices and thus guarantee the closed-loop stability. The use of the identified parameters of various closed-loop systems can solve the problem that the reliable identified parameters, such as natural frequencies, of the open-loop system may not provide enough information for damage detection. Only a small number of sensors are required for the proposed approaches. The identified natural frequencies, which are generally much less sensitive to noise and more reliable than the identified mode shapes, are used for damage detection. Two damage detection techniques are presented. One technique is based on the structures with direct

*Research Professor, Center of Excellence in Information Systems. Senior Member AIAA

†Principal Scientist, Structural Dynamics Branch. Fellow AIAA

output feedback controllers while the other technique uses the second-order dynamic feedback controllers. A least-squares technique, which is based on the sensitivity of natural frequencies to damage variables, is used for accurately identifying the damage variables.

1 Introduction

Reliable and efficient techniques for health monitoring and damage detection of large structures, such as spacecraft and aircraft, are essential for safe operation, maintenance cost reduction, and failure prevention. In the last decade, various vibration-based methods have been proposed [1-6]. These methods are more globally sensitive to damage than localized conventional methods such as ultrasonic and eddy current methods [7]. However, the vibration-based algorithms developed so far cannot be considered very efficient and effective. For example, the widely used finite element (FE) model-update techniques [1,2] require many sensors to measure mode shapes, but the number of sensors is limited in practical applications.

In general, the identified mode shapes are much more sensitive to noise and environmental uncertainty than the identified natural frequencies. On the other hand, the natural frequencies are sensitive to structural damage, such as stiffness loss and cracking. Thus, the identified natural frequencies are more reliable for damage detection than the identified mode shapes. In real applications, the identified natural frequencies of the open-loop system may not provide enough information for damage detection, because the number of the reliable natural frequencies may be smaller than the number of the possible damage elements. To solve this problem, some researchers have proposed the use of the “Twin” structures, where a structure is attached to the tested structure, for damage detection [8,9]. The concept of

physical attachment of structures may limit the application of this technique.

In this paper, we use the natural frequencies of the closed-loop systems with virtual passive controllers [10,11]. Recently, various techniques have been developed for the applications of passive controllers [10-15]. When a virtual passive controller is applied to a flexible structure, the system is almost always augmented with damping regardless of the system size. In theory, no matter what happens, the controller, which resembles mass-spring-dashpot, won't destabilize the system because it is an energy dissipative device. In performing the damage detection, the virtual passive controller only uses the existing control devices and no additional physical elements are attached to the system. The proposed techniques have the advantages of flexibility of controller design and placement.

In this paper, two damage detection techniques based on different control techniques are proposed. First, consider only the direct output feedback, implying the absence of the dynamics in the feedback controller. In this circumstance, the number of the natural frequencies of the closed-loop system is the same as that of the open-loop system. Second, assume that the feedback controller contains a set of second-order dynamic equations. It is equivalent to visualize a virtual passive damping system, i.e. the feedback controller, which is linked side by side to the real flexible body. In other words, two sets of second-order dynamic equations are coupled to generate a closed-loop system. The number of natural frequencies of the closed-loop system is the summation of the order of the open-loop system and the order of the controller.

In on-line health monitoring, first, system identification techniques are used to process experimental data to obtain the identified natural frequencies of open-loop and closed-loop systems. Then, a least-squares technique, which is based on the sensitivity of natural fre-

quencies to the variables of damage, is used for detecting the damage variables. Examples are given to demonstrate and verify the presented approaches.

2 Direct Output Feedback

In this section, we present a damage detection algorithm that is based on a system with a direct output feedback controller. In the analysis and design, the second order dynamic equation of structural vibration is used

$$M\ddot{x} + D\dot{x} + Kx = Bu \quad (1)$$

$$y = C_a\ddot{x} + C_v\dot{x} + C_dx. \quad (2)$$

Here x is an $n \times 1$ displacement vector, and M, D , and K are mass, damping, and stiffness matrices, respectively. In the measurement equation, y is the $q \times 1$ measurement vector, and C_a, C_v and C_d are acceleration, velocity, and displacement influence matrices. The measurement equation may be used either directly or indirectly for a feedback controller design. Here we use the direct feedback, and the input vector u is

$$u = -Fy = -FC_a\ddot{x} - FC_v\dot{x} - FC_dx. \quad (3)$$

Substituting Eq. (3) into Eq. (1) yields

$$(M + BFC_a)\ddot{x} + (D + BFC_v)\dot{x} + (K + BFC_d)x = 0. \quad (4)$$

In this paper, the changes of the identified natural frequencies of the tested system are used for damage detection.

To illustrate the approach, consider the eigenvalue problem of a second-order dynamic system without a damping term. The eigensystem of the open-loop system can be written

as

$$(\omega_{oi}^2 M(z) + K(z))\phi_i = 0, \quad (5)$$

where ω_{oi} is the i th natural frequency corresponding to the i th eigenvector ϕ_i , and z is the vector of damage variables such as the stiffness losses of elements. The r -dimensional damage vector z is defined as

$$z = [z_1 \ z_2 \ \dots \ z_r]^T, \quad (6)$$

where z_i is the i th damage variable, for example the value of z_i is 1 when the i th element has 0% stiffness loss and the value of z_i is 0.5 when the i th element has 50% stiffness loss.

The natural frequency vector of the open-loop system is defined as

$$\omega_o = [\omega_{o1} \ \omega_{o2} \ \dots \ \omega_{on}]^T. \quad (7)$$

There are n natural frequencies for this second-order dynamic system. The number r of the damage variables may be larger than n . In this situation, the use of the natural frequencies of the open-loop system may not provide enough information to identify the r -dimensional damage vector z . To solve this problem, let us include the identified natural frequencies of the m closed-loop systems with different direct feedback controllers. The eigensystem of the j th closed-loop system is expressed as

$$((\omega_{ci}^j)^2 M_t^j(z) + K_t^j(z))\phi_i = 0, \quad (8)$$

where ω_{ci}^j is the i th eigenvalue of the j th closed-loop system, M_t^j and K_t^j are mass and stiffness matrices of the j th closed-loop system, respectively. Each closed-loop system has n natural frequencies. The natural frequency vectors of these m closed-loop systems are computed as

$$\begin{aligned} \omega_c^1 &= [\omega_{c1}^1 \ \omega_{c2}^1 \ \dots \ \omega_{cn}^1]^T \\ \omega_c^2 &= [\omega_{c1}^2 \ \omega_{c2}^2 \ \dots \ \omega_{cn}^2]^T \end{aligned} \quad (9)$$

⋮

$$\omega_c^m = [\omega_{c1}^m \ \omega_{c2}^m \ \dots \ \omega_{cn}^m]^T.$$

Then the system natural frequency vector, which includes the open-loop system and the m closed-loop systems, is defined as

$$\omega = [\omega_o^T \ (\omega_c^1)^T \ (\omega_c^2)^T \ \dots \ (\omega_c^m)^T]^T. \quad (10)$$

From the Taylor's series expansion, the natural frequency vector ω can be expressed as a function of damage variables

$$\omega(z + \Delta z) = \omega(z) + A(z)\Delta z + \dots \quad (11)$$

with

$$A = \begin{bmatrix} \frac{\partial \omega_o}{\partial z_1} & \frac{\partial \omega_o}{\partial z_2} & \dots & \frac{\partial \omega_o}{\partial z_r} \\ \frac{\partial \omega_c^1}{\partial z_1} & \frac{\partial \omega_c^1}{\partial z_2} & \dots & \frac{\partial \omega_c^1}{\partial z_r} \\ \vdots & \vdots & \ddots & \vdots \\ \frac{\partial \omega_c^m}{\partial z_1} & \frac{\partial \omega_c^m}{\partial z_2} & \dots & \frac{\partial \omega_c^m}{\partial z_r} \end{bmatrix}, \quad (12)$$

where A is the $n(m+1) \times r$ sensitivity matrix of natural frequency to damage variables. The sensitivity of the closed-loop system can be enhanced by choosing feedback controllers [16]. The number m is chosen to satisfy the inequation

$$n(m+1) \geq r. \quad (13)$$

The linear approximation of Eq. (11) is

$$\omega(z + \Delta z) \approx \omega(z) + A(z)\Delta z. \quad (14)$$

Eq. (14) can be written as

$$A(z)\Delta z \approx \omega(z + \Delta z) - \omega(z) = \Delta \omega. \quad (15)$$

The least-squares techniques can be used to obtain the approximated solution of Δz as

$$\Delta z \approx (A^T A)^{-1} A^T \Delta \omega. \quad (16)$$

To detect the damage variables $z_i, i = 1, \dots, r$ accurately, we apply the following procedures:

1. Compute the updated natural frequency vector $\omega(z_{new})$ (from Eqs. (5) and (8)) as a function of the updated z_{new} , where the initial z_{new} corresponds to the healthy structure.
2. Compute the difference between the identified natural frequency vector ω_t , which corresponds to the tested system, and the updated vector $\omega(z_{new})$ as

$$\Delta \omega = \omega_t - \omega(z_{new}). \quad (17)$$

3. Compute the sensitivity matrix $A(z_{new})$.
4. Use the linear approximation to compute the updated variables

$$\Delta z = (A^T A)^{-1} A^T \Delta \omega \quad (18)$$

$$z_{new} = z_{old} + \Delta z. \quad (19)$$

5. Check if $|\Delta z| \leq$ precision error specified.

- (a) Yes, stop (b) No, go to 1.

The parameters used for damage detection are not limited to the identified natural frequencies. For example, consider an n -degree-of-freedom spring-mass system with single input and l displacement outputs. The transfer functions of the open-loop system are

$$g_j(s) = \sum_{i=1}^n \frac{b_{ji}}{s^2 + \omega_{oi}^2}, \quad j = 1, 2, \dots, l, \quad (20)$$

where g_j is the transfer function corresponding to the j th displacement sensor. The parameter vector of this open-loop system is defined as

$$p_o = [\omega_{o1} \dots \omega_{on} b_{11} \dots b_{1n} \dots b_{l1} \dots b_{ln}]^T. \quad (21)$$

The dimension of the parameter vector p_o is $(l + 1)n$. We can also include the parameter vectors $p_c^j, j = 1, \dots, m$ corresponding to the m closed-loop systems, and then define the system parameter vector as

$$p = [p_o^T (p_c^1)^T (p_c^2)^T \dots (p_c^m)^T]^T. \quad (22)$$

The augmented parameter vector p can then be used for the identification of the damage vector z .

In the least-squares procedures, the updated variables in Eq. (19) can be computed as [17,18]

$$z_{new} = z_{old} + \alpha \Delta z \quad (23)$$

with

$$\Delta z = (A^T A)^{-1} A^T \Delta \omega$$

where α is the learning rate [17], which is chosen to make the difference between the updated ω and the identified ω_t smaller. In the design process, we choose controllers and the number of the closed-loop systems to make $A^T A$ full rank without ill-condition. Other optimization techniques, such as Newton's method and Conjugate Gradient method [17,18], can also be applied to compute the solution of z and solve the problem of the singularity of $A^T A$.

3 Controller with Second-Order Dynamics

In this section, we present a damage detection method in which the feedback controller is described as a set of second-order dynamic equations

$$M_c \ddot{x}_c + D_c \dot{x}_c + K_c x_c = B_c u_c \quad (24)$$

$$y_c = C_{ac} \ddot{x}_c + C_{vc} \dot{x}_c + C_{dc} x_c. \quad (25)$$

Here x_c is the controller state vector of dimension n_c , and M_c, D_c , and K_c are the controller mass, damping and stiffness matrices, respectively. The quantities $M_c, D_c, K_c, C_{ac}, C_{vc}$, and C_{dc} are the design parameters for the controller. Let the input vectors u and u_c be

$$u = y_c = C_{ac} \ddot{x}_c + C_{vc} \dot{x}_c + C_{dc} x_c \quad (26)$$

$$u_c = y = C_a \ddot{x} + C_v \dot{x} + C_d x. \quad (27)$$

Substituting Eq. (26) into Eq. (1) and Eq. (27) into Eq. (24) yields

$$M_t \ddot{x}_t + D_t \dot{x}_t + K_t x_t = 0, \quad (28)$$

where

$$M_t = \begin{bmatrix} M & -BC_{ac} \\ -B_c C_a & M_c \end{bmatrix}, \quad D_t = \begin{bmatrix} D & -BC_{vc} \\ -B_c C_v & D_c \end{bmatrix} \quad (29)$$

$$K_t = \begin{bmatrix} K & -BC_{dc} \\ -B_c C_d & K_c \end{bmatrix}, \quad x_t = \begin{bmatrix} x \\ x_c \end{bmatrix}. \quad (30)$$

In the controller design, $M_c, D_c, K_c, C_{ac}, C_{dc}$, and C_{vc} are chosen such that the closed-loop system is stable [10,11]. This closed-loop system has $n + n_c$ natural frequencies. For damage detection, we use the identified natural frequencies of m closed-loop systems with different controllers, where the dimension of the controller state vector x_c is assumed to be a constant

n_c for simplicity of presentation. The vectors of natural frequencies of these m closed-loop systems are computed as

$$\begin{aligned}\omega_c^1 &= [\omega_{c1}^1 \ \omega_{c2}^1 \ \dots \ \omega_{c,n+n_c}^1]^T \\ \omega_c^2 &= [\omega_{c1}^2 \ \omega_{c2}^2 \ \dots \ \omega_{c,n+n_c}^2]^T \\ &\vdots \\ \omega_c^m &= [\omega_{c1}^m \ \omega_{c2}^m \ \dots \ \omega_{c,n+n_c}^m]^T.\end{aligned}\tag{31}$$

Then the natural frequency vector of the m closed-loop systems is defined as

$$\omega = [(\omega_c^1)^T \ (\omega_c^2)^T \ \dots \ (\omega_c^m)^T]^T,\tag{32}$$

where ω is a vector of $(n + n_c)m$ dimension. To find the solution of r -dimensional vector z , m needs to satisfy the following inequality

$$(n + n_c)m \geq r.\tag{33}$$

To obtain solutions of the damage variables $z_i, i = 1, \dots, r$, we use the identified natural frequencies of these m closed-loop systems and apply the least-squares technique in the preceding section. The identified natural frequencies of the open-loop system can also be included for damage detection, and the parameters used for damage detection are not limited to the identified natural frequencies.

4 Spring-Mass Example

A spring-mass system with two-degrees of freedom is used for the study. First, the results with the direct output feedback are presented. Then, the results with the dynamic feedback controller are discussed.

4.1 Direct Output Feedback

Consider a spring-mass system with two-degrees of freedom illustrated in Figure 1. The dynamic equation of this system is

$$\begin{bmatrix} m_1 & 0 \\ 0 & m_2 \end{bmatrix} \begin{bmatrix} \ddot{x}_1 \\ \ddot{x}_2 \end{bmatrix} + \begin{bmatrix} k_1 + k_2 & -k_2 \\ -k_2 & k_2 \end{bmatrix} \begin{bmatrix} x_1 \\ x_2 \end{bmatrix} = \begin{bmatrix} 0 \\ 1 \end{bmatrix} u. \quad (34)$$

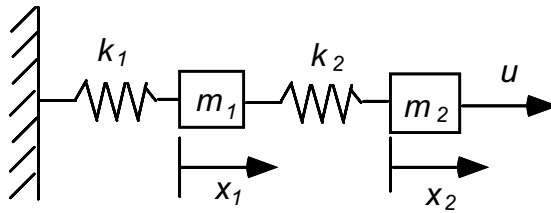

Figure 1: Two-degree-of-freedom system

Table 1: Parameters of the two-degree spring-mass system.

m_1	m_2	k_1	k_2
3	1	50	80

Table 1 lists the values of the four parameters of this system. Using the displacement measurement at x_2 , the input u can be expressed as

$$u = -cx_2. \quad (35)$$

Substituting Eq. (35) into Eq. (34) yields

$$\begin{bmatrix} m_1 & 0 \\ 0 & m_2 \end{bmatrix} \begin{bmatrix} \ddot{x}_1 \\ \ddot{x}_2 \end{bmatrix} + \begin{bmatrix} k_1 + k_2 & -k_2 \\ -k_2 & k_2 + c \end{bmatrix} \begin{bmatrix} x_1 \\ x_2 \end{bmatrix} = 0. \quad (36)$$

In this example, the results are based on the analysis of the open-loop system and three closed-loop systems with different output feedback

$$u_1 = -3x_2, \quad u_2 = -10x_2, \quad u_3 = -x_2.$$

In the first case, each parameter (m_i or k_i) has a small reduction of 5%. To find the solution of these four parameters, we need to use at least two systems, since the open-loop system or each closed-loop system has 2 natural frequencies. Table 2 shows the results when the natural frequencies of the open-loop system and the closed-loop system with the first controller are used. In this minor damage case, each parameter has a reduction of 0.2%. Each parameter converges to the true one with a negligible error in one iteration. When the natural frequencies of the open-loop system and three closed-loop systems are used, the results are the same as that in Table 2.

Table 2: Case 1 Results from open-loop and one closed-loop systems.

iteration No.	m_1	m_2	k_1	k_2
1	2.9940	0.9980	49.900	79.840
True	2.9940	0.9980	49.900	79.840

Table 3: Case 2 Results.

iteration No.	m_1	m_2	k_1	k_2
1	4.2087	1.5595	30.733	53.115
2	4.8997	1.9251	30.001	50.324
3	4.9985	1.9980	30.000	50.001
4	5.0000	2.0000	30.000	50.000
True	5.0000	2.0000	30.000	50.000

In the second case, each parameter has a significant change, m_1 changes from 3 to 5, m_2 changes from 1 to 2, k_1 reduces from 50 to 30, k_2 reduces from 80 to 50. Table 3 shows the results when the natural frequencies of the open-loop system and the first closed-loop system are used. Each parameter converges to the true value after 4 iterations when all the parameters have significant changes.

4.2 Controller with Second-Order Dynamics

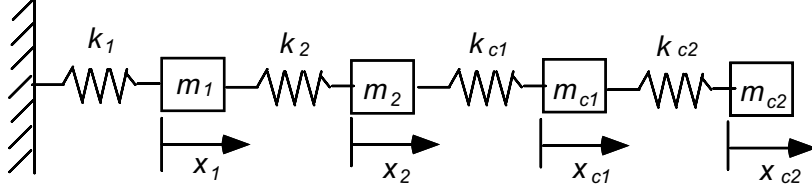

Figure 2: Two-degree-of-freedom system with a two-degree-of-freedom dynamic controller

Consider the preceding two-degrees-of-freedom system with a two-degrees-of-freedom dynamic controller as shown in Figure 2. The second-order controller design in this case is simply

$$u = k_{c1}(x_{c1} - x_2), \quad (37)$$

where the controller dynamic equations of x_{c1} and x_{c2} are solved by

$$\begin{bmatrix} m_{c1} & 0 \\ 0 & m_{c2} \end{bmatrix} \begin{bmatrix} \ddot{x}_{c1} \\ \ddot{x}_{c2} \end{bmatrix} + \begin{bmatrix} k_{c1} + k_{c2} & -k_{c2} \\ -k_{c2} & k_{c2} \end{bmatrix} \begin{bmatrix} x_{c1} \\ x_{c2} \end{bmatrix} = \begin{bmatrix} 0 & k_{c1} \\ 0 & 0 \end{bmatrix} \begin{bmatrix} x_1 \\ x_2 \end{bmatrix}. \quad (38)$$

The dynamic equation of the closed-loop system is

$$\begin{bmatrix} m_1 & 0 & 0 & 0 \\ 0 & m_2 & 0 & 0 \\ 0 & 0 & m_{c1} & 0 \\ 0 & 0 & 0 & m_{c2} \end{bmatrix} \begin{bmatrix} \ddot{x}_1 \\ \ddot{x}_2 \\ \ddot{x}_{c1} \\ \ddot{x}_{c2} \end{bmatrix} + \begin{bmatrix} k_1 + k_2 & -k_2 & 0 & 0 \\ -k_2 & k_2 + k_{c1} & -k_{c1} & 0 \\ 0 & -k_{c1} & k_{c1} + k_{c2} & -k_{c2} \\ 0 & 0 & -k_{c2} & k_{c2} \end{bmatrix} \begin{bmatrix} x_1 \\ x_2 \\ x_{c1} \\ x_{c2} \end{bmatrix} = 0. \quad (39)$$

This closed-loop system has 4 natural frequencies, so only one closed-loop system is required for obtaining the solution of four parameters. The results are based on the analysis of two closed-loop systems with different controllers having the parameters listed in Table 4.

Table 4: Parameters of two passive dynamic controllers.

	m_{c1}	m_{c2}	k_{c1}	k_{c2}
Cont. 1	5	3	200	100
Cont. 2	1	3	50	80

In the first case, the parameter changes are the same as those in Case 1 of the preceding direct output feedback example. Table 5 shows the results when the natural frequencies of the first closed-loop system are used. In this minor damage case, each parameter has a reduction of 0.2%. Each parameter converges to the true one with a negligible error in one iteration. When the natural frequencies of both closed-loop systems are used, the results are the same as that in Table 5.

Table 5: Case 1 Results from one closed-loop system.

iteration No.	m_1	m_2	k_1	k_2
1	2.9940	0.9980	49.900	79.840
True	2.9940	0.9980	49.900	79.840

Table 6: Case 2 Results.

Iteration No.	m_1	m_2	k_1	k_2
1	4.6310	1.5974	17.659	72.878
2	4.5499	1.8666	25.804	42.743
3	5.0150	1.9941	29.737	49.870
4	4.9999	2.0000	29.999	50.000
True	5.0000	2.0000	30.000	50.000

In Case 2 of this example, each parameter has a significant change, which is the same as the one in Case 2 of the direct output feedback example. Table 6 shows the results when the natural frequencies of the first closed-loop system are used. All the parameters converge to the true values after 4 iterations when all the parameters have significant changes.

Comparing the results in Tables 2 and 5, both techniques can accurately identify the damage variables in one iteration when the parameter changes are insignificant. From Tables

3 and 4, both techniques can successfully identify the damage variables in a few iterations when parameters have significant changes.

5 Euler's Beam Example

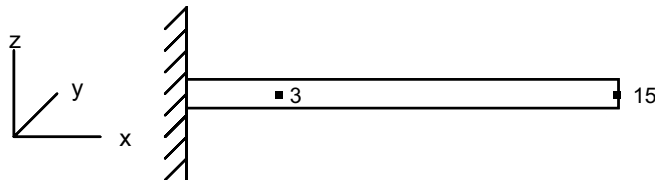

Figure 3: Cantilevered Euler's beam

The second structure used for study is a cantilevered aluminum Euler's beam, as shown in Figure 3. The length, width, and thickness of this beam are 1, 0.0254, and 0.000635 meters, respectively. The study is based on the analysis of the finite element model of this beam structure [19]. For the structural damage, we consider the stiffness loss of 15 elements of equal length from the fixed end to the free end. The damage variables $z_i, i = 1, \dots, 15$, which correspond to the 15 elements, are 1 for the healthy structure. If the stiffness reduction of the i th element is $a\%$, then the value of z_i is $1-0.01a$. For example, the value of z_i is 0.5, when the stiffness loss of the i th element is 50%.

5.1 Direct Output Feedback

In the direct output feedback example, we use two displacement measurements located at positions 3 and 15, respectively. The first closed-loop system has the collocated output feedback controller at position 3. The second closed-loop system has the collocated output

feedback controller at position 15. The natural frequencies of the first 10 modes of the open-loop system and the two closed-loop systems are used for damage detection.

Table 7: Case 1 Results.

iteration No.	1	True
z_1	1.0000	1.0000
z_2	1.0000	1.0000
z_3	1.0000	1.0000
z_4	1.0000	1.0000
z_5	0.99800	0.99800
z_6	1.0000	1.0000
z_7	1.0000	1.0000
z_8	0.99800	0.99800
z_9	1.0000	1.0000
z_{10}	1.0000	1.0000
z_{11}	0.99800	0.99800
z_{12}	1.0000	1.0000
z_{13}	1.0000	1.0000
z_{14}	1.0000	1.0000
z_{15}	1.0000	1.0000

Tables 7 and 8 show the results of damage detection for two different cases. In Case 1, elements 5, 8 and 11 each have 0.2% stiffness loss. The solution of each parameter in the first iteration converges to the true one. The results in Table 10 show that all the parameters converge to the true ones after 5 iterations when 6 elements have significant stiffness reductions.

Table 8: Case 2 Results.

iteration No.	1	2	3	4	5	True
z_1	0.9670	1.0101	1.0018	1.0000	1.0000	1.0000
z_2	0.6375	0.6864	0.6980	0.7000	0.7000	0.7000
z_3	0.9802	1.0023	1.0046	0.9999	1.0000	1.0000
z_4	0.5084	0.6012	0.5989	0.6000	0.6000	0.6000
z_5	0.6846	0.7523	0.7981	0.8000	0.8000	0.8000
z_6	1.1144	1.0388	0.9950	1.0000	1.0000	1.0000
z_7	0.9174	0.9801	1.0017	1.0000	1.0000	1.0000
z_8	0.6405	0.6925	0.6993	0.7000	0.7000	0.7000
z_9	1.0857	1.0284	0.9975	1.0000	1.0000	1.0000
z_{10}	0.8670	0.9488	0.9998	1.0000	1.0000	1.0000
z_{11}	0.8522	0.8255	0.7970	0.8000	0.8000	0.8000
z_{12}	1.0392	0.9948	1.0039	0.9999	1.0000	1.0000
z_{13}	0.8776	0.9682	0.9952	1.0000	1.0000	1.0000
z_{14}	0.5773	0.6071	0.5997	0.6000	0.6000	0.6000
z_{15}	0.9764	1.0153	1.0053	0.9999	1.0000	1.0000

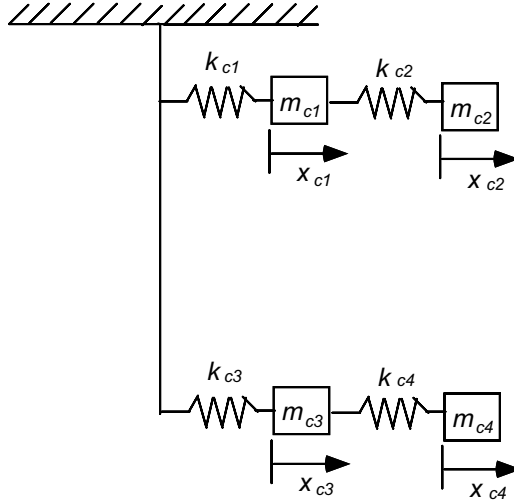

Figure 4: Cantilevered Euler's beam with passive dynamic controllers

5.2 Controller with Second-Order Dynamics

Two passive systems, which are spring-mass systems with two-degrees-of-freedom (Figure 4), are attached to positions 3 and 15, respectively. The results of damage detection are based on the analysis of two closed-loop systems with controllers of different designed variables as listed in Table 9. The natural frequencies of the first 12 modes of two closed-loop systems are used. In Case 1, elements 5, 8 and 11 each have 0.2% stiffness loss. Each parameter converges to the true one in one iteration, and the results are the same as that shown in Table 7. The results in Table 10 show that all the parameters converge to the true ones after 5 iterations when 6 elements have significant stiffness reductions.

Table 11 lists the first 10 natural frequencies of the open-loop system and the four closed-loop systems, which include the preceding two closed-loop systems with direct output feedback and the preceding two closed-loop systems with passive dynamic controllers. The natural frequencies of the first 3 modes have relatively significant changes when the displace-

Table 9: Design variables of controllers.

	Controller 1	Controller 2
m_{c1}	0.08	0.32
m_{c2}	0.16	0.24
m_{c3}	0.24	0.16
m_{c4}	0.32	0.08
k_{c1}	70	140
k_{c2}	140	70
k_{c3}	140	70
k_{c4}	70	140

Table 10: Case 2 Results.

iteration No.	1	2	3	4	5	True
z_1	0.8916	0.9600	1.0015	0.9999	1.0000	1.0000
z_2	0.9711	0.6987	0.6933	0.7000	0.7000	0.7000
z_3	1.0211	1.0596	1.0036	1.0001	1.0000	1.0000
z_4	0.6541	0.6397	0.5975	0.6000	0.6000	0.6000
z_5	0.9504	0.8848	0.7915	0.8000	0.8000	0.8000
z_6	0.9890	0.9576	0.9887	0.9999	1.0000	1.0000
z_7	0.7979	0.9494	1.0072	1.0000	1.0000	1.0000
z_8	0.4471	0.6455	0.6984	0.7000	0.7000	0.7000
z_9	0.7410	0.8829	1.0012	0.9999	1.0000	1.0000
z_{10}	0.8122	0.9416	0.9989	1.0000	1.0000	1.0000
z_{11}	0.7451	0.7628	0.8034	0.8000	0.8000	0.8000
z_{12}	1.0017	0.9552	0.9916	0.9999	1.0000	1.0000
z_{13}	1.0535	1.0141	1.0042	0.9998	1.0000	1.0000
z_{14}	0.7395	0.6145	0.5922	0.5999	0.6000	0.6000
z_{15}	0.9904	1.0583	1.0335	0.9984	1.0000	1.0000

Table 11: Natural frequencies of various systems.

ω_i	Open	Direct 1	Direct 2	Dynamic 1	Dynamic 2
$i=1$	0.2314	0.4074	0.9297	0.0385	0.0576
2	1.4571	1.3465	1.8906	0.6854	0.5064
3	4.1401	4.3181	4.4665	1.5921	1.5126
4	8.3103	8.2954	8.3300	3.5606	3.5784
5	14.1798	14.2440	14.2698	4.6111	4.7958
6	21.9843	21.9771	22.0034	7.9502	8.1083
7	31.9425	31.9397	31.9570	10.0531	9.9792
8	44.1603	44.1765	44.1789	15.8172	16.7393
9	58.5049	58.5086	58.5024	20.7861	22.0166
10	74.4921	74.5023	74.4978	28.6436	26.3393

ment output feedback is used, meanwhile the natural frequencies of the high frequency modes change little. This may limit the application of the direct output feedback approach since noise and environmental uncertainty may have significant effect on the identified natural frequencies of the high frequency modes. All the natural frequencies of the two closed-loop systems with passive dynamic controllers change significantly.

The advantage of direct output feedback technique is its simplicity because the feedback controller is directly from the output measurements. The use of the controller with a passive dynamic system has the following advantages: (1)flexibility of adjusting natural frequencies, (2)variety of choice of passive controllers, (3)increase of the number of the effective natural frequencies, which are reliable in the considered low frequency range. In real applications, we can combine these two techniques and use the advantages of both techniques for damage detection.

6 Conclusions

This paper presents novel approaches for structural damage detection by adding virtual passive controllers to structures. The controller is passive in the sense that it contains mechanisms that serve only to transfer and dissipate energy to the system. Stabilization can be accomplished by a controller with gains interpreted as virtual mass, spring, and dashpot elements. Both damage detection techniques, which are based on the direct output feedback and the feedback controller with second-order dynamic equations, can efficiently identify damage in the presented examples when the damage variables have minor as well as significant changes. In this paper only the identified natural frequencies are used for damage detection, since the identified natural frequencies are generally more reliable than the identified mode shapes. Only a small number of sensors are required for the presented approaches. The advantage of direct output feedback technique is its simplicity. The technique with the controller of passive dynamic system has the advantages of flexibility and variety. In real applications, one may combine the advantages of both techniques for damage detection.

Acknowledgments

This research is supported in part by NASA Grant NCC5-228 and NSF Grant HRD-9706268. These supports are greatly appreciated.

References

¹Jauregui, D. V., and Farrar, C. R., “Comparison of Damage Identification Algorithms on Experimental Modal Data from a Bridge,” *Proceedings of the 14th International Modal Analysis Conference*, 1996, pp. 1423-1429.

²Zimmerman, D. C., and Kaouk, M., “Structural Damage Detection Using a Subspace Rotation Algorithm,” *Proceedings of the 33th AIAA/ASME/AHS/ASC Structures, Structural Dynamics, and Materials Conference*, AIAA, Washington, DC, 1992, pp. 2341-2350.

³Lew, J.-S., “Using Transfer Function Parameter Changes for Damage Detection of Structures,” *AIAA Journal*, Vol. 33, No. 11, 1995, pp. 2189-2193.

⁴Pandey, A. K., Biswas, M., and Samman, M., “Damage Detection from Changes in Curvature Mode Shapes,” *Journal of Sound and Vibration*, Vol. 145, No. 2, 1991, pp. 321-332.

⁵Smith, S. W., and Beattie, C. A., “Secant-Method Adjustment for Structural Models,” *AIAA Journal*, Vol. 29, No. 1, 1991, pp. 119-126.

⁶Lew, J.-S., “Damage Detection Using Neural Networks and Transfer Function Correlation,” *Proceedings of the 18th International Modal Analysis Conference*, San Antonio, Texas, February 7 - 10, 2000, pp. 1783-1789.

⁷Ness, S., and Sherlock, C. N., “Nondestructive Testing Handbook, Vol. 10, Nondestructive Testing Overview,” *American Society for Nondestructive Testing*, 1996.

⁸Trivailo, P., Plotnikova, L.A. and Wood, L.A.* Enhanced Parameter Identification for

Damage Detection and Structural Integrity Assessment Using "Twin" Structures (Invited Paper). - *Fifth International Congress on Sound and Vibration*, University of Adelaide, SA, 15-18 December 1997, pp.1733-1741.

⁹Trivailo, P. and Plotnikova, L. (1999) * High Sensitivity Damage Identification in 3D Modular Structures: Improved Modal Analysis Technique, International Conference on Application of Modal Analysis'99 "Recent Advances in Modal Analysis Practice", 15-17 December 1999, Gold Coast, Queensland, Australia, pp.1-14.

¹⁰Juang, J. N., and Phan, M., "Robust Controller Designs for Second-Order Dynamic Systems: A Virtual Passive Approach", *Journal of Guidance, Control and Dynamics*, Vol. 15, No. 5, Sept-Oct. 1992, pp. 1192-1198.

¹¹Bruner, A. M., Belvin, W. K., Horta, L. G., and Juang, J. N., "Active Vibration Absorber for the CSI Evolutionary Model Design and Experimental Results," *Journal of Guidance, Control and Dynamics*, Vol. 15, No. 5, Sept-Oct. 1992, pp. 1253-1257.

¹²Juang, J. N., Wu, S. C., Phan, M., and Longman, R. W., "Passive Dynamic Controllers for Non-Linear Mechanical Systems," *Journal of Guidance, Control and Dynamics*, Vol. 16, No. 5, Sept.-Oct., 1993, pp. 845-851.

¹³Morris, K. A. and Juang, J.-N., "Dissipative Controller Designs for Second-Order Dynamic Systems," *IEEE Transactions on Automatic Control*, Vol. 39, No. 5, May 1994, pp. 1056-1063.

¹⁴Lee-Glauser, G., Juang, J.-N., and Sullia, J. L., "Optimal Active Vibration Absorber: Design and Experimental Results," *Journal of Vibration and Acoustics*, Vol. 117, No. 2, April 1995, pp. 165-171.

¹⁵Chuang, C.-H., Courouge, O., and Juang, J.N., "A Robust Controller for Second-Order Systems Using Acceleration Measurement," *Journal of Dynamic Systems, Measurement, and Control*, Vol. 119, No. 2, June 1997, pp. 350-354

¹⁶Ray, L. R., and Tian, L., "Damage Detection in Smart Structures through Sensitivity Enhancing Feedback Controller," *Journal of Sound and Vibration*, 227(5), pp. 987-1002, Nov. 1999.

¹⁷Hagan, M. T., Demuth, H. B., and Beale, M., *Neural Network Design*, PWS Publishing Company, Boston, 1996.

¹⁸G. V. Reklaitis, A. Ravindran, and K. M. Ragsdell, *Engineering Optimization: Methods And Applications*, John Wiley & Sons, Inc., New York, 1983.

¹⁹Craig, R. R., *Structural Dynamics: An Introduction to Computer Method*, Wiley, New York, 1981.

REPORT DOCUMENTATION PAGE			Form Approved OMB No. 0704-0188
Public reporting burden for this collection of information is estimated to average 1 hour per response, including the time for reviewing instructions, searching existing data sources, gathering and maintaining the data needed, and completing and reviewing the collection of information. Send comments regarding this burden estimate or any other aspect of this collection of information, including suggestions for reducing this burden, to Washington Headquarters Services, Directorate for Information Operations and Reports, 1215 Jefferson Davis Highway, Suite 1204, Arlington, VA 22202-4302, and to the Office of Management and Budget, Paperwork Reduction Project (0704-0188), Washington, DC 20503.			
1. AGENCY USE ONLY (Leave blank)	2. REPORT DATE December 2001	3. REPORT TYPE AND DATES COVERED Technical Memorandum	
4. TITLE AND SUBTITLE Structural Damage Detection Using Virtual Passive Controllers		5. FUNDING NUMBERS WU 706-32-21-01	
6. AUTHOR(S) Jiann-Shiun Lew and Jer-Nan Juang			
7. PERFORMING ORGANIZATION NAME(S) AND ADDRESS(ES) NASA Langley Research Center Hampton, VA 23681-2199		8. PERFORMING ORGANIZATION REPORT NUMBER L-18118	
9. SPONSORING/MONITORING AGENCY NAME(S) AND ADDRESS(ES) National Aeronautics and Space Administration Washington, DC 20546-0001		10. SPONSORING/MONITORING AGENCY REPORT NUMBER NASA/TM-2001-211251	
11. SUPPLEMENTARY NOTES Lew: Tennessee State University, Nashville, TN; Juang: NASA Langley Research Center, Hampton, VA.			
12a. DISTRIBUTION/AVAILABILITY STATEMENT Unclassified-Unlimited Subject Category 39 Distribution: Nonstandard Availability: NASA CASI (301) 621-0390		12b. DISTRIBUTION CODE	
13. ABSTRACT (Maximum 200 words) This paper presents novel approaches for structural damage detection which uses the virtual passive controllers attached to structures, where passive controllers are energy dissipative devices and thus guarantee the closed-loop stability. The use of the identified parameters of various closed-loop systems can solve the problem that reliable identified parameters, such as natural frequencies of the open-loop system may not provide enough information for damage detection. Only a small number of sensors are required for the proposed approaches. The identified natural frequencies, which are generally much less sensitive to noise and more reliable than the identified natural frequencies, are used for damage detection. Two damage detection techniques are presented. One technique is based on the structures with direct output feedback controllers while the other technique uses the second-order dynamic feedback controllers. A least-squares technique, which is based on the sensitivity of natural frequencies to damage variables, is used for accurately identifying the damage variables.			
14. SUBJECT TERMS Damage detection; Virtual passive control; Energy dissipative control; Dynamic feedback control		15. NUMBER OF PAGES 29	16. PRICE CODE
17. SECURITY CLASSIFICATION OF REPORT Unclassified	18. SECURITY CLASSIFICATION OF THIS PAGE Unclassified	19. SECURITY CLASSIFICATION OF ABSTRACT Unclassified	20. LIMITATION OF ABSTRACT UL