

DEVELOPMENT OF A PROTOTYPE LOW-VOLTAGE ELECTRON BEAM FREEFORM FABRICATION SYSTEM

J.K. Watson^{*}, K.M. Taminger[†], R.A. Hafley[†], and D.D. Petersen^{*}

^{*}NASA Johnson Space Center, Houston, TX 77058

[†]NASA Langley Research Center, Hampton, VA 23681

Abstract

NASA's Langley Research Center and Johnson Space Center are developing a solid freeform fabrication system utilizing an electron beam energy source and wire feedstock. This system will serve as a testbed for exploring the influence of gravitational acceleration on the deposition process and will be a simplified prototype for future systems that may be deployed during long-duration space missions for assembly, fabrication, and production of structural and mechanical replacement components. Critical attributes for this system are compactness, minimal mass, efficiency in use of feedstock material, energy use efficiency, and safety. The use of a low-voltage (<15kV) electron beam energy source will reduce radiation so that massive shielding is not required to protect adjacent personnel. Feedstock efficiency will be optimized by use of wire, and energy use efficiency will be achieved by use of the electron beam energy source. This system will be evaluated in a microgravity environment using the NASA KC-135A aircraft.

INTRODUCTION

Future long-duration human exploration missions will be challenged by constraints on mass and volume allocations available for spare parts. Addressing this challenge will be critical to the success of these missions. As a result, it is necessary to consider new approaches to spacecraft maintenance and repair that minimize the mass and stowage volume that must be allocated for spares while enhancing mission robustness [1].

Production of replacement components by solid freeform fabrication (SFF) processes during a mission could reduce or eliminate the need to carry a complete inventory of pre-manufactured spares. Rather, replacement components would be generated as needed from feedstock material. As a result, only the total mass of replacements would need to be estimated instead of a prediction of which specific components might be needed. Attempting to predict which components will fail and require replacement will inherently be an inaccurate process and will certainly result in provisioning numerous components that will never be used (wasted mass) and may result in under-provisioning of other components. This technology could also be used to support fabrication of large space structures and repair of spacecraft primary structure [2].

Direct deposition processes utilizing laser or electron beam energy sources offer the greatest potential for space applications. Although the feedstock material can be introduced as either a powder or wire, the wire form is preferable for in-space application because of

operational and safety issues associated with management of metallic powder in a microgravity environment. The basic electron beam freeform fabrication (EB F³) process and preliminary results obtained in ground-based experiments are described in reference 3.

Key issues associated with the production of components during space missions center on the potential effects of a microgravity environment on the process. In the microgravity environment, body forces on the molten region of the deposited bead become insignificant and surface tension forces will dominate. Therefore, the cross-sectional shape of the molten region may be different during microgravity deposition than during deposition in a 1-g environment. This will have at least two potentially significant effects. First, the bead cross-section will govern the topography of the exposed surfaces of the final part. The resulting surface condition and associated stress concentrations will affect the mechanical properties of the component. Second, closed-loop process control schemes may rely on monitoring the shape of the molten portion of the deposited bead. Since the bead shape in microgravity may be somewhat different from that in a 1-g environment, it is essential that the nominal shape in microgravity be fully characterized. Also, solidification of the material in the microgravity environment may affect metallurgical characteristics.

For these reasons, an important initial step in developing an SFF process suitable for use in space will be an experimental effort to understand and define the effects of a reduced-gravity environment on the process. For the near term, work will be performed using the NASA Johnson Space Center (JSC) Reduced Gravity Program KC-135A research aircraft because of its accessibility and relatively low cost. As the process and apparatus mature it will be appropriate to take advantage of facilities such as the Space Shuttle or International Space Station. Compactness, low mass, and efficient energy utilization will be essential attributes for SFF system hardware that will be used in any of these facilities. Particularly because of superior energy conversion efficiency compared with laser systems, electron beam technology was chosen for the current effort. This characteristic is an attribute both for the current development system and for future operational systems that may evolve from this work.

The initial phase of the effort will consist of system development and ground-based checkout, initial KC-135A microgravity flight tests, and sample analysis. The primary goals of this phase will be to: (1) develop a working prototype EB F³ system for reduced gravity flight, and (2) evaluate of the effects of a microgravity environment on the metallurgy and geometry of the material deposited with this process.

EXPERIMENTAL SYSTEM DESIGN

An artist's conception and a schematic diagram of the low-voltage EB F³ system being designed for microgravity flight tests are shown in Figures 1 and 2, respectively. The major components that will be contained within the vacuum chamber include the electron beam gun, positioning system, and wire feeder. The electron beam gun and wire feeder will be mounted directly to the top portion of the vacuum chamber. The positioning system and ports for the vacuum system will be mounted to a base that can be dropped down to provide full access to the interior of the chamber when not under vacuum. The mounting brackets will be precision

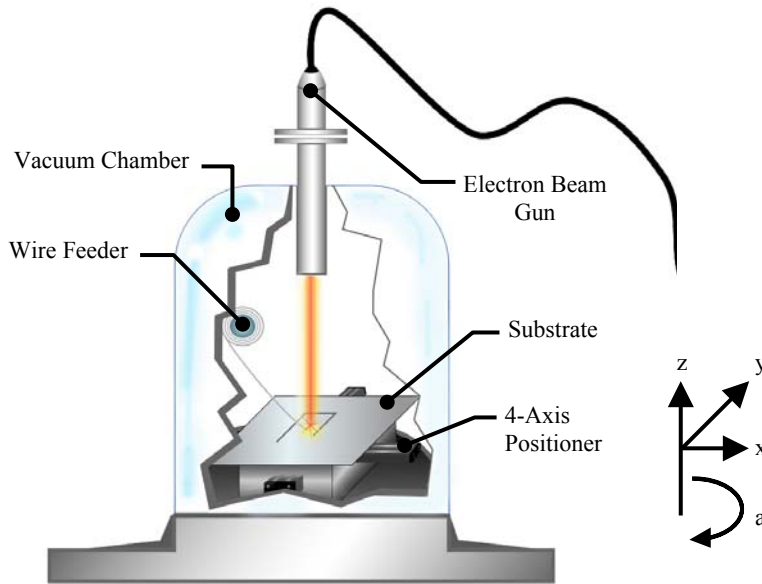

Figure 1. Artist's conception of low-voltage EB F³ system.

aligned to maintain the proper orientation of the electron beam gun and wire feeder with respect to the zero coordinates in the positioning system. The vacuum chamber and all support hardware will be rack-mounted and fastened directly to the KC-135A aircraft.

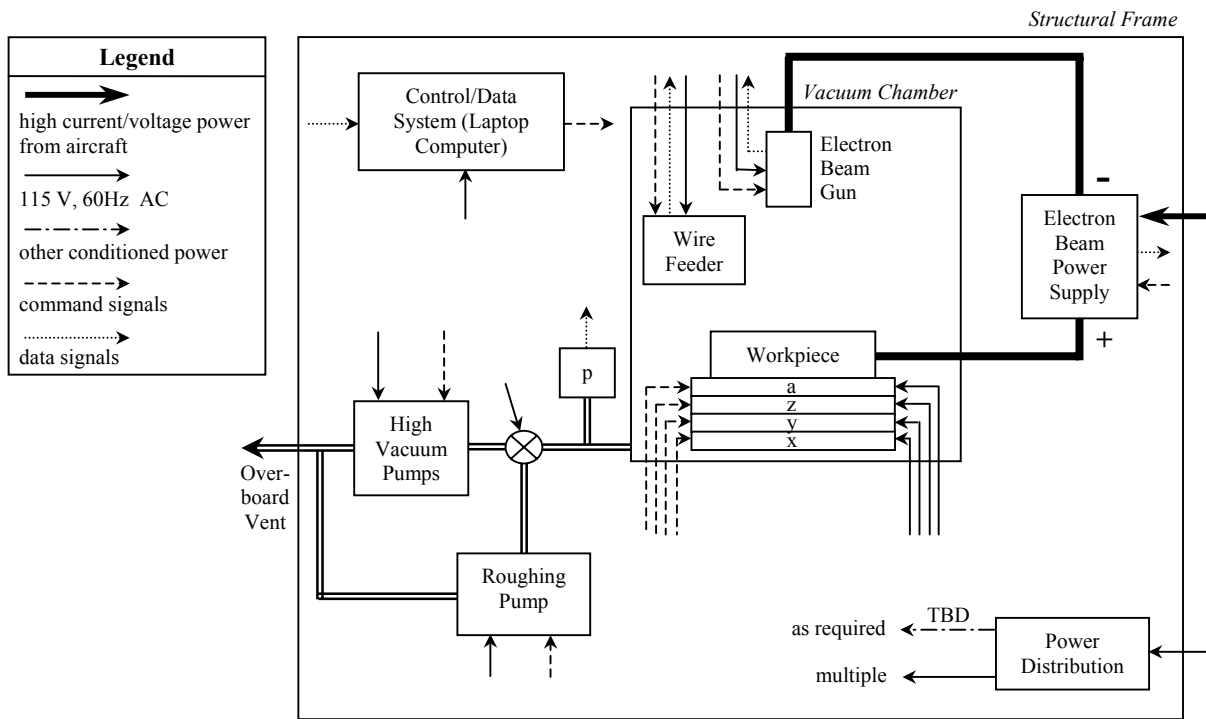

Figure 2. Schematic diagram of low-voltage EB F³ system.

Electron Beam Gun

Conventional electron beam welding operating in the range of 60 kV accelerating voltage generates sufficient x-radiation to pose a serious potential health risk to personnel. This hazard is controlled by incorporating sufficient lead shielding in the walls and window of the vacuum chamber. Clearly, massive shielding would be counter to the objective of developing a lightweight, portable system for use on research aircraft. Further, the mass associated with this shielding would be a very undesirable characteristic for an operational system to be used onboard spacecraft. Since heavy shielding is undesirable in this application, the alternative approach is to design the process in such a way that production of hazardous penetrating radiation is avoided. This can be accomplished by operating at significantly lower accelerating voltages than are typically used for industrial electron beam welding. Operation in the range of 8 – 15 kV will minimize production of penetrating radiation [4]. Shielding provided by a simple stainless steel or aluminum vacuum chamber should be adequate to ensure the safety of operating personnel [5].

The electron beam gun will generate a focusable low-voltage beam with a maximum beam power of 3-5 kW and will operate using 110 V input power. This design was selected to provide sufficient power density for the EB F³ process and still meet safety considerations for radiation shielding. The gun is compact in size and operates using the vacuum from the process environment, thereby eliminating the requirement for auxiliary vacuum pumping of the gun. The filament will be selected for robustness and long life. As shown in the schematic in Figure 2, the electron beam system is designed for an electrically conductive path to ground the system to the aircraft.

Vacuum System

The electron beam deposition process must be performed in a vacuum to prevent attenuation of the electron beam and ionization of gases in the process environment. This also provides a clean atmosphere to prevent contamination of the metal during the deposition process. The vacuum level needs to be a minimum of 10⁻⁵ torr for proper operation of the electron beam gun. Size, weight, power, and rapid evacuation requirements restrict the choices of vacuum pumps used for the simulated microgravity experiments performed on the KC-135A. In addition, the vacuum system must be robust enough to withstand the cyclic low-g to high-g loading conditions plus any unpredictable loads experienced due to air turbulence. (Further details on the flight conditions are described in the “Aircraft Operations and Safety Requirements” section below.) The final design for this system calls for three vacuum pumps: an oil-less scroll pump, a turbomolecular pump, and an ion pump. The scroll pump will achieve a rough vacuum, and serve as a backing pump for the turbomolecular pump. At approximately 1 torr, the turbomolecular pump will switch on to evacuate quickly down to the 10⁻⁶ torr range. Once the chamber reaches 10⁻⁶ torr, the valve to the turbomolecular pump will be closed and the pump shut off to protect the high speed rotating vanes from damage that may occur due to sudden loading or changes in gravitational forces on the pump. The ion pump will then be turned on to maintain high vacuum and to remove any outgassing or metal vapor resulting from the EB F³ process. A further precautionary measure will be to mount the pumps with shock

suppression to protect them from damage due to irregular loading conditions as a result of the parabolic flight trajectories and unforeseen aerodynamic turbulence.

In space, the equipment can be designed and operated to use the vacuum of space as the process environment for the EB F³ process. The processing equipment might either be located such that it can be fully exposed to the space environment or located in a working chamber that is vented overboard. In either case, use of the high vacuum readily available in space will significantly simplify the EB F³ system design by eliminating the vacuum system.

Positioning System

The positioning system has been designed to move the substrate while allowing the electron beam to remain stationary. This approach does not maximize efficiency of the build envelope, but it significantly simplifies the system design. The position where the wire is fed into the focal point of the electron beam is a fixed point. This allows for cameras to easily be positioned to monitor the process and provide feedback control. The positioning system has four axes: X, Y, and Z linear axes, plus a-axis rotation in the X-Y plane. During the weightless portions of the flight, the deposition will occur while translating in the X-Y plane using X and Y linear travel and/or rotation to build a single layer. During the high-g portions of the flight, the deposition process will be suspended and the substrate will be indexed down in the Z-direction a distance equal to the height of the previous layer, then repositioned in X, Y, and rotated back to a starting point in preparation for the next pass. This initial approach will maintain a constant angle between the wire feed orientation and the translation direction. The four-axis system allows sufficient flexibility for more detailed process development and the ability to produce more complex parts in the future.

The positioning system has been designed specifically for the EB F³ process. The precision and accuracy of the positioning system are specified to be smaller than the molten pool. The translation speed ranges are designed to allow a large process envelope in which control of the build height and width and deposition rates can be optimized for specific structural features and metallurgical characteristics. The mechanisms are covered to protect them from contamination with condensed metal vapor from the EB F³ process. In addition, the positioning system is thermally and electrically isolated from the process zone to protect it from the heat and electrical current generated by the electron beam. The motors are vacuum-compatible and contained within the chamber.

Wire Feed System

The feedstock form selected for this process is metal wire. Powdered metal feedstock requires gravity or flowing gas to direct the powder into the molten pool. For operating in a vacuum at microgravity, neither of these powder delivery methods will work. In addition, containment and handling of powdered metal poses significant safety issues in a microgravity environment. The use of wire feedstock eliminates the need for flowing gas and provides nearly 100% feedstock usage efficiency, resulting in the minimum mass and virtually no waste products. The wire feeder is capable of feeding very small diameter wires at both high and low speeds, enabling a range of deposition rates and fine detail to be achieved within this EB F³ system. The one-pound

wire spools and the wire feed system will be vacuum compatible for location within the vacuum system close to the process zone.

Instrumentation

The instrumentation for the low-voltage EB F³ system is designed to measure processing conditions and record data throughout the processing, indexed on a common time scale. All of the controls and data acquisition will be programmed through a LabView interface on a PC laptop computer. The vacuum chamber will be equipped with multiple viewing ports for mounting high speed and standard video cameras to visually record the active process zone during microgravity. Accelerometers will be attached to the equipment to measure the gravitational forces and accelerations. In addition, beam parameters, vacuum levels, positioning, and wire feeder control parameters will be recorded on the same time base to match with the process monitoring instrumentation outputs. Additional electrical feedthroughs will be incorporated into the vacuum chamber wall to allow implementation of other monitoring devices, such as thermocouples, for future experiments.

Aircraft Operations and Safety Requirements

Testing of the EB F³ system in a reduced gravity environment will be conducted aboard NASA's KC-135A aircraft. Specially modified for the reduced gravity operations and maneuvers, the aircraft flies along a trajectory in a series of parabolas. Weightlessness, from partial gravity to zero-g depending upon the specific trajectory flown, is experienced during the top portion of the parabola. Up to 1.8-g may be felt during the pull-out and bottom of the parabola, and then again during the initial pull-up (ascent). The expected time for reduced gravity is 20 to 23 seconds for each parabola, with a standard of 40 parabolas per flight.

Because the time of reduced gravity is short-lived, the objectives of the experiment must be concise and well planned to be completed within the 20 second zero-g period; otherwise, the results of the research can be jeopardized by the affects of the 1.8-g pull-out. In addition, many other requirements must be met, both for the test engineers (medical certification consisting of a flight-rated physical, and physiological training) and the flight experiments.

Prior to flight a test equipment data package will be submitted and will include a test plan, engineering drawings, structural analysis, electrical loads analysis, and all identifiable hazards. The electron beam freeform fabrication system will operate on 110 volt AC, 60 Hz, single phase input power, one of four available power interfaces provided for aircraft payloads. The system will also be designed to handle the possible occurrence of brief power interruptions during flight. For contingency purposes, structural analysis will be performed to verify the experimental hardware and all major components will withstand the maximum, worst case, take-off and crash-landing loads of 9-g's.

As previously mentioned, a form of shock suppression will be used on the vacuum pumps to dampen the 1.8-g effects experienced during pull-out and ascent. However, all subsystems and components will require either test or analysis to verify their operation through the 1.8-g maneuvers, including components in the positioning system. Other items to evaluate will

include any inherent risks of the vacuum system, and requirements for overboard venting of outgases and metal vapors resulting from the EB F³ process.

PLANNED TEST PROGRAM AND SYSTEM EVOLUTION

The low-voltage EB F³ system as described in this report will be tested on the ground prior to flight testing on board the KC-135A. This will serve to work out the test matrix and provide baseline parts constructed in a 1-g environment. Experiments conducted on the KC-135A will be used to study the effects of microgravity on the geometry of the molten pool, the resulting build geometry, and solidification microstructure. Different molten pool diameters will be explored to examine regions where the process is surface tension dominated (with a small diameter molten pool) as compared to being dominated by gravitational forces (with a larger diameter molten pool). Research with another ground-based EB F³ system at NASA Langley will focus on exploring process parameter domains and defining acceptable operating envelopes through correlation of processing, microstructure, and mechanical properties [3]. Processing parameters will be developed for a variety of alloys of interest for aerospace structures, including aluminum, aluminum-lithium, and titanium alloys. In addition, comparing parts built using the low-voltage system with those built in the ground-based system at NASA LaRC will assess reproducibility and robustness of the EB F³ process.

The low-voltage EB F³ system has been designed to allow for adding capabilities for enhancing the process controls. Such evolution may include addition of the ability to change the orientation of the wire feed angle into the molten pool, extended part manipulation capabilities, development of closed-loop controls and process automation, and the ability to build parts directly from computer-aided design (CAD) files. The results of testing performed in 1-g and microgravity environments will assist in deciding the appropriate directions and capabilities to be developed in future efforts to enable the deployment and application of such a system in support of human exploration missions.

SUMMARY

Electron beam freeform fabrication (EB F³) is a new process being developed that has promise for supportability of long-duration human exploration missions of space. Therefore, NASA's Langley Research Center and Johnson Space Center are building a low-voltage EB F³ system to test in a microgravity environment on board the KC-135A research aircraft. Considerations for KC-135A requirements and the effect of the microgravity environment on the hardware and process are built into the system design for the electron beam gun, vacuum, positioning, and wire feed. Experiments are described to develop the processing envelope and understand the effects of microgravity on the geometry of the molten pool, the resulting build geometry, and solidification microstructure from the EB F³ process.

REFERENCES

- [1] Watson, K., D. Petersen, and R. Crockett, "Application of Solid Freeform Fabrication Technology to NASA Exploration Missions," in Proceedings, 10th Solid Freeform Fabrication Symposium, Austin, TX: University of Texas at Austin, pp. 857 – 864, (1999).
- [2] Taminger, K. M. B., R. A. Hafley, and D. L. Dicus, "Solid Freeform Fabrication: An Enabling Technology for Future Space Missions," in Proceedings, 2002 International Conference on Metal Powder Deposition for Rapid Manufacturing, San Antonio, TX: Metal Powder Industries Federation, pp. 51-60, (2002).
- [3] Taminger, K. M. B., and R. A. Hafley, "Characterization of 2219 Aluminum Produced by Electron Beam Freeform Fabrication," in Proceedings, 13th Solid Freeform Fabrication Symposium, Austin, TX: University of Texas at Austin (2002).
- [4] Edwards, D. L., "Absorbed Dose Determination using Experimental and Analytical Predictions of X-Ray Spectra," PhD Dissertation, August 1999, Department of Mechanical Engineering, Auburn University.
- [5] Hernandez, J., NASA-JSC Internal Memorandum, June 26, 2002.