



AIAA 2000-1042

**Overview of Conceptual Design
of Early VentureStar™ Configurations**

M. K. Lockwood

NASA Langley Research Center

Hampton, VA 23681

**38th Aerospace Sciences
Meeting & Exhibit**
10-13 January 2000 / Reno, NV

OVERVIEW OF CONCEPTUAL DESIGN OF EARLY VENTURESTAR™ CONFIGURATIONS

M.K. Lockwood*
NASA Langley Research Center
Hampton, VA 23681

ABSTRACT

One of NASA's goals is to enable commercial access to space at a cost of \$1000/lb (an order of magnitude less than today's cost) by approximately 2010. Based on results from the 1994 Congressionally mandated, NASA led, Access-to-Space Study, an all rocket-powered single-stage-to-orbit reusable launch vehicle was selected as the best option for meeting the goal. To address the technology development issues and the follow-on development of an operational vehicle, NASA initiated the X-33 program. The focus of this paper is on the contributions made by the NASA Langley Research Center (LaRC), from 1997-1998, to the conceptual design of the Lockheed Martin Skunk Work's (LMSW) operational reusable single-stage-to-orbit VentureStar™ vehicle. The LaRC effort has been in direct support of LMSW and NASA Marshall Space Flight Center (MSFC). The primary objectives have been to reduce vehicle dry weight and improve flyability of the VentureStar™ concepts. This paper will briefly describe the analysis methods used and will present several of the concepts analyzed and design trades completed.

NOMECLATURE

EELV	Enhanced Expendable Launch Vehicle
CFD	Computational Fluid Dynamics
cg	Center of Gravity
GLOW	Gross Lift Off Weight
ISS	International Space Station
LaRC	NASA Langley Research Center
LH2	Liquid Hydrogen
LMSW	Lockheed Martin Skunk Works
LOX	Liquid Oxygen

**Research Engineer, Vehicle Analysis Branch,
Aerospace Systems Concepts and Analysis Competency,
Member AIAA.*

Copyright © 2000 American Institute of Aeronautics and Astronautics, Inc. No copyright is asserted in the United States under Title 17, U.S. Code. The U.S. Government has a royalty-free license to exercise all rights under the copyright claimed herein for Governmental purposes. All other rights are reserved by the copyright owner.

LQR	Linear Quadratic Regulator
MSFC	NASA Marshall Space Flight Center
RCS	Reaction Control System
RLV	Reusable Launch Vehicle
SSTO	Single Stage to Orbit
TPS	Thermal Protection System

BACKGROUND

One of NASA's goals is to enable commercial access to space at a cost of \$1000/lb (an order of magnitude less than today's cost) by approximately 2010. Based on results from the 1994 Congressionally mandated, NASA led, Access-to-Space Study, an all rocket-powered single-stage-to-orbit (SSTO) reusable launch vehicle (RLV) was selected as the best option for meeting the goal. However, the study also concluded that significant advances in technology would be required before such a vehicle would be feasible. To address the technology development issues and the follow-on development of an operational vehicle, NASA initiated the X-33 program. A multiple industry partner/NASA Phase I study, starting in 1994, was followed by a competition for the Phase II Program in 1996. Phase II, currently on-going, includes the design, build and flight test of a technology demonstrator vehicle (the X-33); a ground test program to demonstrate critical technologies not tractable or cost effective for inclusion in the X-33 demonstrator; and the conceptual-through-preliminary design of an operational, economically viable reusable launch vehicle. Following the conclusion of Phase II a decision will be made jointly by industry and NASA whether or not to proceed with the detailed design and fabrication of a reusable launch vehicle and corresponding infrastructure.

NASA awarded Lockheed Martin Skunk Works the X-33 Phase II contract. LMSW's operational single-stage-to-orbit vehicle concept, known as VentureStar™, is a lifting body vehicle with an aft-mounted linear aerospike engine. An early VentureStar™ configuration is shown in Figure 1. LMSW's X-33 demonstrator vehicle, shown in Figure 2, is an approximately linear half scale technology demonstrator version of the operational vehicle.



Figure 1. Early VentureStar™ Configuration.



Figure 2. X-33 Configuration.

**DESIGN DECISIONS TO ACHIEVE
LOW COST SSTO**

Given that the SSTO reusable launch vehicle must enable commercially viable access to space, several requirements are imposed on the vehicle, including mission, operability, weight and performance requirements. Mission requirements for VentureStar™ incorporate both the NASA International Space Station (ISS) re-supply mission and a wide range of commercial missions. The NASA ISS mission requires delivery of a 25,000 lb payload to the 51.6 deg inclination, 248 nmi Station orbit. Payload bay length requirements for this mission have ranged from 30 ft during the Access-to-Space study to 45 ft, all at 15-ft diameter. The payload bay length requirement for commercial payloads is driven by such missions as delivery of satellites to geo-transfer orbit. To compete for these payloads, with other commercial launch systems, such as the Enhanced Expendable Launch Vehicles (EELVs), Venture-

Star™ is looking to accommodate payloads up to 45' to 60' in length. This is a significant growth in the payload bay size requirement since the Access-to-Space Study, and has a significant impact on the vehicle design.

To achieve the order of magnitude reduction in cost per pound to orbit, the Access to Space Study concluded that the vehicle must be fully reusable, with the frequency of maintenance actions significantly reduced as compared to today's Space Shuttle. This requirement impacts the technologies selected for VentureStar™. For example, the RS-2200 engine is a gas-generator cycle aerospike engine compared to the Space Shuttle Main Engines, which are fuel rich staged combustion engines. The objective for the aerospike engine is to achieve a similar level of performance compared to that of the Shuttle Main Engines, but at lower operating pressures, to reduce the maintenance requirements. The aerospike engine is not new technology, with engine designs and testing dating back to the 1960's; however, no aerospike engine has been flown to anchor the integrated performance and demonstrate the technology. Testing the demonstrator version of the aerospike in the X-33 flight tests is one of the most important aspects of the X-33 program.

Another technology selected to improve operability is the metallic thermal protection system (TPS). One of the highest maintenance items on the Space Shuttle is the ceramic TPS. For example, each individual tile must be inspected following every flight. The damaged tiles, the majority of which are unique designs, are individually tagged and recorded for replacement or repair. In addition, selected tiles must be rewaterproofed. The VentureStar™ team is employing metallic TPS panels to reduce the maintenance requirements and is also striving to maximize the panel commonality over as much of the vehicle acreage as possible. Compared to ceramic tile TPS however, the maximum temperature limitations of the metallic TPS are lower. Therefore the entry trajectory design space is reduced for a vehicle with metallic TPS panels compared to a vehicle with ceramic TPS tiles. The metallic panel concept envisioned for VentureStar™ will be flight-tested on the X-33.

One of the main drivers in the cost of the VentureStar™ vehicle is dry weight. Small increases in vehicle dry weight, due to increases in component weights for example, at a given vehicle size, result in large increases in closed vehicle size and weight. (ref 1) (A closed vehicle is achieved when the propellant required to achieve the mission is equal to the propellant available on the vehicle.) Composite structure was identified in the Access-to-Space Study as one of the enabling technologies to achieve commercially viable weights for reusable SSTO vehicles, and was baselined for the VentureStar™. Use of this technology for producing

large scale primary composite structures, such as for the LOX and LH2 tanks, intertank, and thrust structure is still in its infancy. Problems with the X-33 LH2 tanks have caused LMSW to reconsider metallic tanks for VentureStar™. (ref 2)

Another of the key challenges resulting from the decision to develop a rocket-powered SSTO is configuring a flyable vehicle throughout the flight corridor. With engines mounted aft on the vehicle, and the fuel tanks empty, the cg is typically farther aft on a rocket-powered SSTO vehicle during entry than for a staged vehicle such as the Space Shuttle. The result is an increase in the contribution of the vehicle body to the aerodynamic moments and a reduction in the effectiveness of the aft aerodynamic surfaces. Thus, to enable trim and to provide control effectiveness, the cg either has to be shifted forward with ballast, or the area of the aft aerodynamic surfaces must be increased up to meet the trim and stability requirements. (In some cases aerodynamic control surfaces can be moved forward, but with a resultant increase in static instability.) The cg location is also a function of vehicle sizing. For example, if the vehicle must be sized up for closure, the cg moves aft since the engine weight, which is sized on gross lift off weight (GLOW), increases faster than the dry weight of the remainder of the vehicle. Adding to the challenge of designing a flyable configuration, the aerodynamic forces and moments vary widely as the vehicle flies through the Mach and angle-of-attack regimes from entry to landing.

OBJECTIVE AND APPROACH

Given the list of technologies selected to meet the program objectives, and the selection of the lifting body linear aerospike engine configuration, the design space for the VentureStar™ configuration is defined. Within this design space, the top two systems-level objectives in the conceptual design of the VentureStar™ vehicle are to minimize vehicle weight to achieve the 25,000 lb of payload to ISS with acceptable margin, and to ensure a flyable configuration throughout the flight corridor. The approach taken was to analyze and understand the early baseline VentureStar™ concept, calibrate the conceptual-level design tools for application to the VentureStar™-class lifting body vehicle, support analyses and trades on the baseline VentureStar™ concepts and to brainstorm and assess “out-of-the-box” concepts aimed at weight reduction and flyability improvements.

Note that the focus of this paper, and the session of papers (refs 3-7) presented at the 38th AIAA Aerospace Sciences Meeting, summarizes NASA LaRC's contribution to the conceptual design of LMSW's operational reusable single-stage-to-orbit VentureStar™ vehicle. The LaRC

effort, 1997-1998, has been in direct support of LMSW and NASA MSFC. While the material presented here is on LaRC's contribution, the vehicle is a LMSW concept and all decisions regarding what and how results are incorporated into the design are made by LMSW.



ANALYSIS METHODS

The set of analysis tools used in the conceptual analysis and design trades is shown in Table 1. During the rapid brainstorming and configuration trade work, particular aspects of a given concept dictated the type and level of analysis completed to assess the merits of the concept. Some concepts could be eliminated based on estimated feasibility of manufacturing processes; some could be eliminated through performance and control assessment; some required rapid layout, weight and flyability assessment. In the latter case for example, a configuration was designed and packaged, the weight and cg determined using CONSIZ (LaRC's Configuration sizing program, ref 8) and the aerodynamics were predicted using APAS (LaRC's engineering-level aerodynamics program, ref 9) corrected with deltas off of an earlier configuration. (The aerodynamic surfaces are sized iteratively between APAS and CONSIZ, since changing the size of the surfaces changes both the aerodynamic forces and moments, and the vehicle cg.) The end result is a configuration that meets the trim and flyability requirements at the screening conditions, and a weight and cg estimate for that configuration. POST was then used with aerodynamic and propulsion databases, and mass property inputs to determine the achievable payload to orbit for the given vehicle size. In this example, if a configuration passed the screening and looked promising, additional analyses were performed to further refine the vehicle. The analysis methods and approach are further described below.

As a starting point in the VentureStar™ analysis, CONSIZ was correlated to the X-33 and Reference Vehicle VentureStar™ mass properties. CONSIZ was then used as the basis for configuration trades, vehicle sizing and sensitivity analyses. As configuration trades progressed,

Table 1. Conceptual Design Tools

		Lead	Conceptual	Preliminary	Detailed
Aerodynamics	APAS	LaRC			
	FELISA	LaRC/MIT			
	Experimental	LaRC			
Aerothermal	MINIVER	LaRC			
	Experimental	LaRC			
Propulsion	Aerospike	LaRC			
Trajectory, GNC	POST	LaRC			
	MATLAB	C			
Geometry	I-DEAS	C			
Structures	MDM	LaRC			
TPS	TPS_size, EXITS	LaRC			
Weights & Sizing	CONSIZ	LaRC			

At given design level:  In progress  Standard use

however, it became clear that additional detail was required in the structural weight prediction input to CONSIZ. The lack of detail in existing structural weight prediction methods made it difficult to differentiate between various vehicle concepts within the design space. Since no single-stage-to-orbit vehicle has ever been built, and only limited data is available on the performance and weight of cryogenic composite tanks and primary structure (available data is also on configurations different than the VentureStar™ design), the usual historical weights data, typically relied on in conceptual design, is sparse. Some method to differentiate between the concepts was needed. Both LMSW and LaRC (ref 3), independently developed higher fidelity parametric weights models. Instead of having a smeared unit weight for the tanks for example, the new tools divide the tank into barrels, domes, joints, etc. Results from these methods, combined with the assessment of vehicle packaging efficiency, performance, and flyability assessment enable differentiation among the various proposed concepts. Although there are still design features that require a closer look than available in the new tools, they offer significant improvement in structural weight prediction over those used in the Access-to-Space Study.

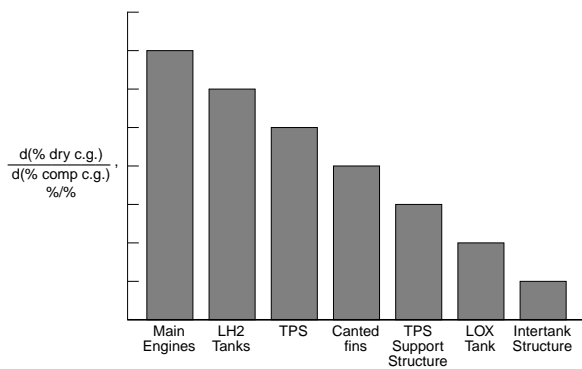

Figure 3. Percent change in vehicle dry weight cg as a result of a percent change in the component cg location.

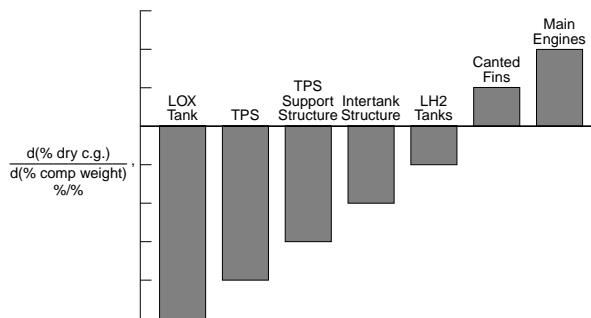

Figure 4. Percent change in vehicle dry weight cg as a result of a percent change in component weight.

To understand the vehicle cg sensitivity to component weight and packaging, bar graphs were developed as shown in Figures 3 and 4. Figure 3 shows the percent change in the vehicle dry weight cg as a result of a percent change in component cg location. Figure 4 shows the percent change in the vehicle dry weight cg as a result of a percent change in the component weight. The graphs provide a visual understanding of the areas of the vehicle that could be modified or re-configured to yield the greatest shift in vehicle cg, including potential benefits of shifting any of the smaller subsystems forward, and how changes in component mass would impact the cg.

For the LaRC vehicle conceptual design work, a capability to develop aerospoke engine databases for ascent trajectory design and vehicle performance assessment was required. Data was available from Rocketdyne for the aerospoke engine performance at five operating conditions. However a method to complete the engine performance database and to predict the thrust vectoring capability was needed. (The aerospoke uses thrust modulation to produce control instead of gimbaling engines used by the Space Shuttle.) An in-house code (ref 4) incorporating models of the gas generator, combustor, aerospoke nozzle flow field, and nozzle base was developed. Utilizing the Rocketdyne performance data as calibration points, engine performance databases with axial thrust, normal thrust, pitching moment, and specific thrust, all as a function of mixture ratio, power level, thrust vectoring level and altitude were developed for use in the trajectory optimization. This capability was key in determining the performance of the various VentureStar™ configurations in a trimmed ascent, as well as determining if adequate control authority was available from the thrust vectoring nozzles for various configurations.

Figure 5 shows the untrimmed, zero control surface deflection, aerodynamic pitching moment characteristic of the VentureStar™-class of vehicle during a nominal entry trajectory. The vehicle experiences a nose-up pitching moment through hypersonic speeds, changing to a nose-down pitching moment transonically, and finally a nose-up moment subsonically. As cg moves aft, the magnitude of the hypersonic and subsonic nose up pitching moment increases, and the effectiveness of the aerodynamic control surfaces is reduced. This results in an increase in the size of the aerodynamic surfaces required for trim and stability. As the cg moves forward, the subsonic and hypersonic moments decrease but the magnitude of the transonic moment increases. In addition, changes in the configuration shape, such as moving the payload bay external to the upper surface as described in the Configuration Trades section below, can increase the magnitude of the transonic nose-down pitching moment. Thus, looking at the longitudinal characteristics alone, pinch points (areas of small flight cor-

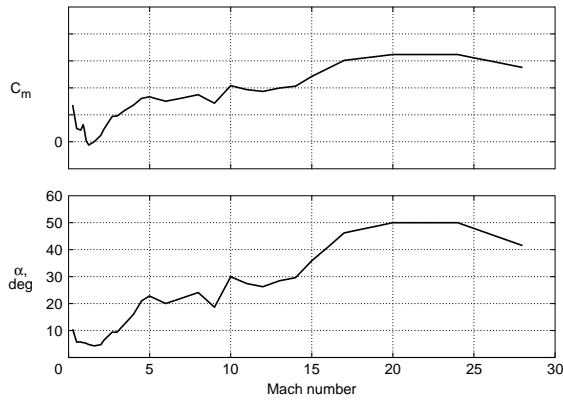

Figure 5. Early VentureStar™ longitudinal aerodynamic characteristics along a nominal entry. Moment is untrimmed with zero degree control surface deflection.

ridor) for the VentureStar™-class configurations, can occur at hypersonic, transonic and subsonic speeds. As a result, across-the-Mach aerodynamic analysis was required throughout the VentureStar™ configuration trades to ensure the design of a flyable vehicle.

APAS has typically been a reliable tool for assessing the subsonic and supersonic to hypersonic aerodynamic performance characterization of launch vehicles, from wing bodies (ref 11) to HL-20 class lifting bodies (ref 12), in the early conceptual phases of design. However, based on comparison to the X-33 wind tunnel data, APAS was not shown to be effective for predicting the pitching moment of this lifting body configuration. This was an unexpected result at the time, and little experimental component build up data was available on the X-33 to determine the reason for the discrepancies. During the VentureStar™ program, configuration build-up data became available for the lifting body configuration. A comparison between pitching moment measured in the LaRC Mach 20 Helium tunnel and APAS is shown in Figures 6 and 7 (ref 13) for an early VentureStar™ configuration. Figure 6 shows the comparison for a complete vehicle, and illustrates the discrepancy in pitching moment trend between the data and APAS, similar to that seen with the X-33. Figure 7 shows the comparison for the body alone. The trends predicted for the body alone between tunnel data and APAS are in reasonable agreement. The results of the comparisons point to a large interference effect between the body and the fins that cannot be captured with APAS. With further analysis, APAS was shown to be acceptable for predicting the aerodynamics of a modified configuration using deltas off of wind tunnel data of similar configurations. For example, APAS could be used to predict the change in pitching moment resulting from a change in fin size.

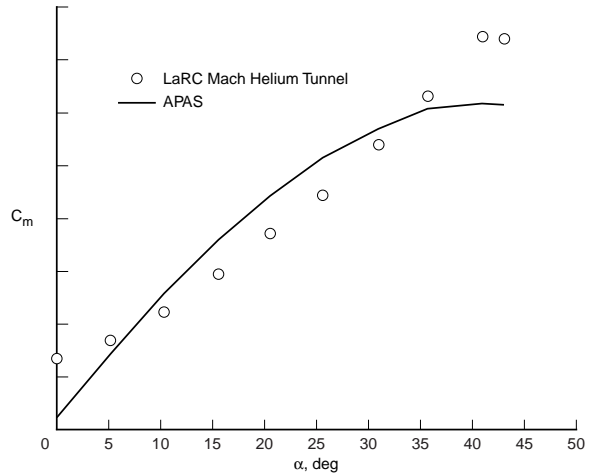

Figure 6. Untrimmed pitching moment with zero control surface deflection for early VentureStar' configuration. Comparison of LaRC Mach 20 Helium tunnel and APAS results.

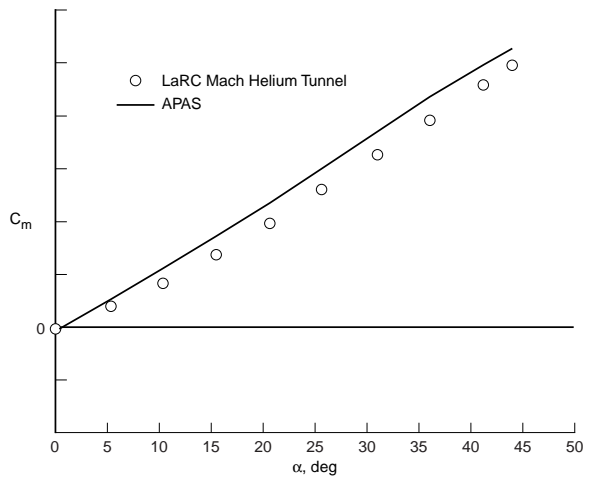

Figure 7. Untrimmed pitching moment for early VentureStar' configuration, body alone. Comparison of LaRC Mach 20 Helium tunnel and APAS results.

FELISA (ref 14), an unstructured Euler CFD code, was also benchmarked against the X-33 aerodynamics. FELISA was shown to predict pitching moment above Mach 1 through hypersonic flight rapidly and accurately at conditions along a typical entry corridor. As a result, FELISA was added to the VentureStar™ conceptual design process to augment APAS. In the transonic regime below Mach 1, viscous effects dominated, requiring higher fidelity, more time consuming Navier Stokes CFD solutions to even predict the correct trends in the aerodynamic coefficients. TETRUS (ref 15), NASA LaRC's unstructured grid Navier Stokes flow solver, was utilized sparingly in this regime for significant configuration changes where the magnitude

of the viscous contribution was uncertain, and an understanding of the flow features was required. (Figure 17 below shows an example comparison of FELISA, TETRUS and MSFC Trisonic wind tunnel data in the transonic regime for a configuration trade.) Finally, the complexity of the aerodynamics for the VentureStar™ configurations indicated that tunnel testing would be required to develop databases for any configurations that departed significantly from any previously tested configurations.

POST (ref 10) is a trajectory simulation code used to optimize both ascent and entry trajectories. The ascent trajectories were designed to minimize propellant required to reach orbit, while meeting constraints on g-loading, normal force, engine operating envelopes and angle-of-attack trim requirements. Entry trajectories were optimized to meet the thermal constraints of the TPS system, while maximizing vehicle cross range capability. The thermal constraints defined for use in POST were based on VentureStar™ analysis using MINIVER (ref 16), a LaRC aerothermal analysis code, in combination with high fidelity experimental and computational aerothermal results completed at LaRC on the X-33 vehicle. Thermal constraints represented in POST included a stagnation point reference heating parameter, correlated to the maximum allowable temperatures on the acreage of the vehicle, and a transition parameter enabling trajectory shaping that would delay the on-set of transition.

Controls feasibility and design was completed using assessments of the open loop characterization of the configurations, a Linear Quadratic Regulator (LQR) approach and a 6-DOF nonlinear simulation. The control law design was developed using a set of linearized longitudinal and lateral/directional equations of motion. The gains were determined using a LQR control design approach with the MATLAB (ref 17) controls functions. Separate linear simulations of the lateral/directional and longitudinal dynamics were completed, allowing a rapid automated method to design and analyze closed loop vehicle responses over the entire trajectory. The robustness of the control law design was then tested with the 6-DOF nonlinear simulation. Results provided include aerodynamic surface deflections and rates, and RCS moment requirements for entry. Angle of attack, sideslip and bank angle responses to maneuver commands are also provided. (ref 6)

Other design tools critical to the LaRC conceptual design work included I-DEAS (ref 18), and TPS_size (ref 19). I-DEAS is a commercial CAD tool, used both for bringing LMSW designs into the LaRC design system and for concept brainstorming and configuration development. TPS_size was used to determine the impact of alternate metallic TPS concepts, designed for increased robustness, on mass properties.

EARLY VENTURESTAR™ REFERENCE VEHICLE

By July 1997, LMSW had begun work on the VentureStar™ configuration known as the 0002a Reference Vehicle, shown in Figure 8. The VentureStar™ Reference Vehicle concept has one forward dual lobe composite LOX tank, a composite intertank, two composite quad lobe LH2 tanks with the payload bay contained between the LH2 tanks, metallic TPS, secondary support structure to support the TPS over the tanks, an aft mounted linear aerospike engine, high dihedral canted fins (37 deg), upper and lower body flaps, two vertical tails, an 18° planform included half angle, and a zero camber flat top, flat bottom body shape. The primary longitudinal structural load path is traced from the aerospike engine, through the inner lobe of the LH2 tank, sheared through the LH2 tank, and taken to the outboard walls of the intertank into the LOX tank.



Figure 8. Early VentureStar™ Reference Vehicle, 0002a.

CONFIGURATION TRADES

Table 2 shows a subset of the configurations explored, including the 0002A starting point, and compares their primary features.

The most significant aerodynamic challenge in the Reference Vehicle configuration was achieving hypersonic trim during entry. Figure 9 shows the hypersonic pitching moment and flap effectiveness for the Reference Vehicle from the hypersonic wind tunnel test, by M. Rhode, in the LaRC 22-Inch, Mach 20 Helium Tunnel. Typical angles of attack at hypersonic speeds on entry are approximately 40-50 deg for these configurations. Thus as shown for the 0002a, trim was not achievable for this configuration with more than 50% of the maximum available body flap deflection. In this case the high dihedral canted fins did not contribute

Table 2. Configuration Characteristics

	LOX Location	Payload % External	# of LOX Tanks	# of LH2 Tanks	LOX Configuration	LH2 Configuration
LMSW 0002A Reference Vehicle	Forward	0	1	2	Dual lobe	Quad lobe
LMSW 0003C	Forward	0	1	2	Dual lobe	Quad lobe
LL5	Forward	100	1	1	Tri lobe	5 Lobe
LL1B	Forward	0	1	2	Dual lobe	Conical
LMSW 0023	Forward	0	1	2	Dual lobe	Quad lobe
LMSW 0023 pooch	Forward	50	1	2	Dual lobe	Quad lobe
LMSW 0033	Forward	50	1	1	Dual lobe	5 Lobe
LA1	Aft	0	2	3	Dual lobe	1 Dual lobe + 2 Quad lobe
LMSW 0028	Aft	100	2	1	Cylindrical	Dual lobe
HFLF	Forward	100	1	1	Dual lobe	Tri lobe

significantly to reduce the nose-up moment. To enable hypersonic trim at acceptable control surface deflections, some combination of lower dihedral, larger canted fins, larger body flaps, or a forward shift in the cg would be required.

The 0003c configuration, shown in Figure 10, was designed at the same time that the tunnel models for the 0002a were being designed and fabricated. The 0003c configuration uses low mounted wings instead of canted fins and body flaps. The concept was based on a winged configura-

tion proposed and tested by LaRC in the X-33 program to address the hypersonic trim issues. The objective was to maximize the effectiveness of the aerodynamic surfaces for longitudinal trim and control authority. Figure 11 shows results, by M. Rhode, from the hypersonic wind tunnel test on the 0003C in the LaRC 22-Inch Mach 20 Helium Tunnel. As shown, a significant improvement in the ability of the configuration to trim resulted. However, updated cg estimates for both the 0002a and 0003c showed the cg farther aft than originally predicted. The wing area would need to

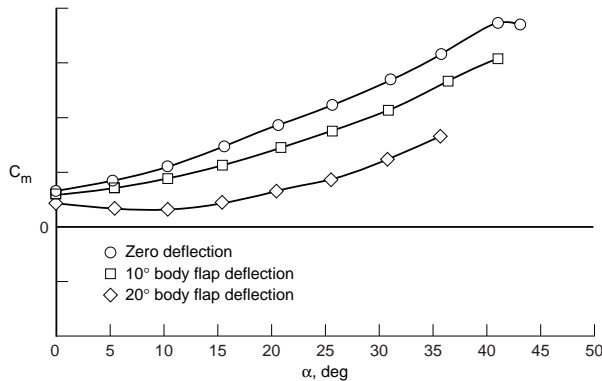

Figure 9. Reference Vehicle hypersonic pitching moment.

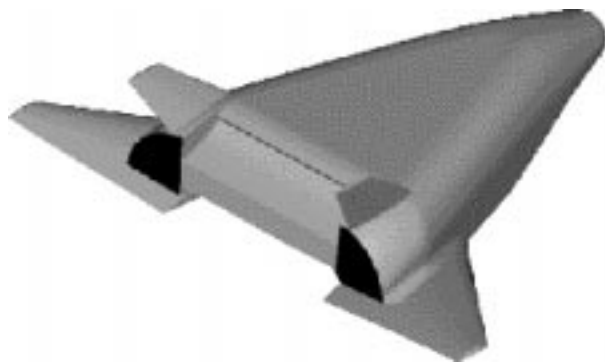

Figure 10. Alternate Control Architecture Configuration, 0003c.

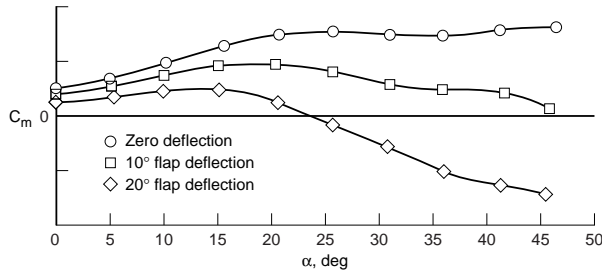

Figure 11. Alternate Control Architecture, 0003c, hypersonic pitching moment.

be increased. Lateral-directional stability of the vehicle was also reduced as compared to the Reference Vehicle. Later configurations have lower dihedral canted fins and body flaps, to maintain the X-33 heritage, but improve the hypersonic trim compared to the Reference Vehicle.

Several concepts and trades were identified to reduce the VentureStar™ weight including improvements in packaging efficiency, minimization of parasitic structure, and improved structural load paths. In all of the trades the basic lifting body shape with the aerospike engine was maintained, although configuration and packaging concepts varied considerably within these constraints. In most of the alternate body configurations, the payload bay was located either partially or completely external to the upper surface of the vehicle. It was identified early in the brainstorming meetings that the fully internal payload bay was leading to significant inefficiencies in the packaging and structural efficiency of the vehicle. A selection of the concepts explored will be presented here.

To address the inefficiencies resulting from the payload bay sandwiched between the two LH2 tanks, and to

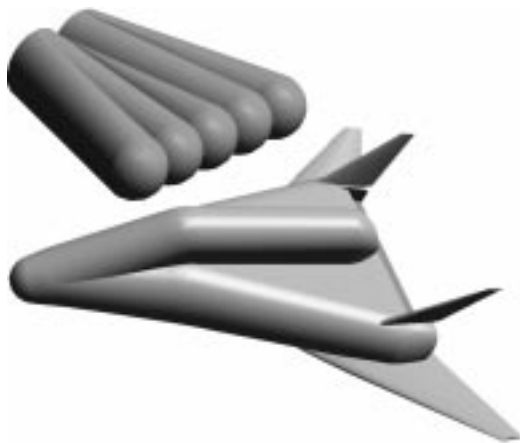

Figure 12. Five lobe single LH2 tank, 100% external payload bay configuration, LL5.

improve the structural loading of the aerospike engine into the LH2 tanks, the LL5 concept shown in Figure 12 was designed. LL5 is a five lobe single LH2 tank concept, with the payload bay 100% external and on top of the vehicle (but still blended in with the vehicle upper skin). The increased packaging efficiency of the concept resulted in a beneficial reduction in overall dry weight for a fixed propellant mass. However, potential aerodynamic challenges including lateral directional stability, longitudinal trim and stability (particularly transonic), and potential airframe propulsion interaction jet effects, associated with the large payload on top of the vehicle resulted. Note that LL5 also incorporated nested LH2 and LOX domes, again to improve packaging efficiency. LL5 also included a tri-lobe LOX tank in an effort to utilize the volume in the blend between the vehicle nose and the payload bay. The latter was eliminated both because of load path complexity and complexity of manufacture. The LL5 single LH2 tank concept was later adopted by LMSW as noted below.

Further assessing packaging, the Reference Vehicle concept had significant secondary support structure between the tank and the TPS, and correspondingly large standoff distances. An analysis was completed (ref 19) to determine the sensitivity of the closed vehicle dry weight to the stand-off distance between the tank walls and the outer moldline of the vehicle, as shown in Figure 13. The analysis found that a 2.5% decrease in closed vehicle weight could be achieved for every inch of reduced stand-off distance. Future VentureStar™ configurations were designed with reduced stand-off distances from that carried on the Reference Vehicle.

At the same time that the LL5 and other concepts were investigated, LL1B was designed. The objective for LL1B was to design a concept with simplified tank geometry and simplified load paths while still meeting the lifting body shape requirement. As shown in Figure 14, the vehicle uti-

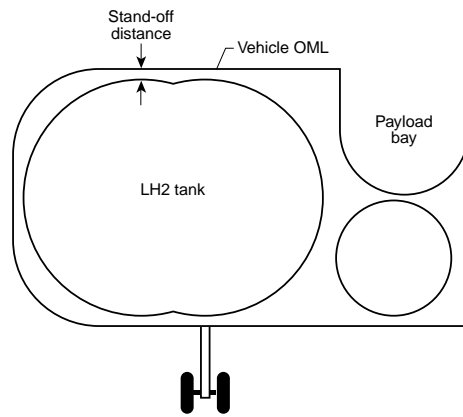

Figure 13 Stand-off distance and packaging efficiency.

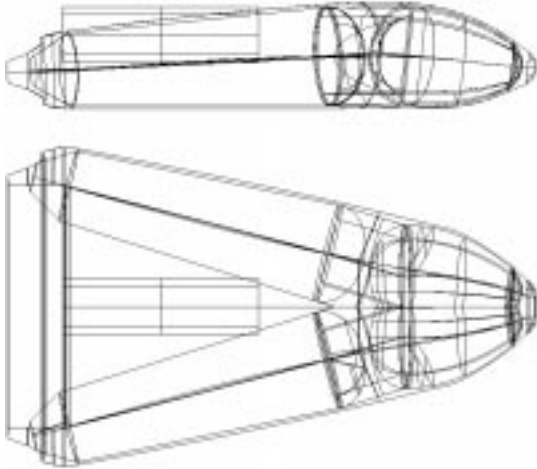

Figure 14. Simplified tank geometry configuration, LL1B.

lized two conical LH2 tanks, instead of the two quad lobe LH2 tanks of the baseline configuration. The thrust structure was a structural beam with tanks simply supported at either end. Although the LL1B offered significant simplification in tank manufacture and load path, the packaging of conical tanks in the lifting body shape showed significant volumetric inefficiencies.

The LMSW 0023 concept took a partial step toward improving the packaging efficiency by “pooching” (an LMSW term for an external payload bay) the payload bay out of the top of the vehicle slightly more than 50%, but maintaining the two quad lobe LH2 tanks. LMSW data at the time indicated that a “100% pooch” might be aerodynamically unacceptable. Figures 15, 16, and 17 show results of inviscid FELISA calculations by K. Bibb and in Figure 17, viscous TETRUS calculations, by P. Parikh, (ref 20) comparing the pooch-on vs. pooch-off results of transonic pitching moment. As shown, the pooch results in significantly more nose-down pitching moment compared to the fully internal payload design. This effect as well as the lateral/directional and propulsion/airframe interaction effects will need to be considered, particularly as the configuration changes to a 100% pooch geometry.

In the LMSW 0033 design, LMSW adopted both the single LH2 tank design, but with a reduced radius central lobe, and a ~50% pooched payload bay. The latest approach for VentureStar™ (ref 2) incorporates the 100% pooched configuration with sized-up low dihedral canted fins, with tip fins.

Other concepts that were explored in parallel with the LL5 and LL1 included various LOX aft concepts, as shown in Figure 18. In a LOX forward concept, the full load of the

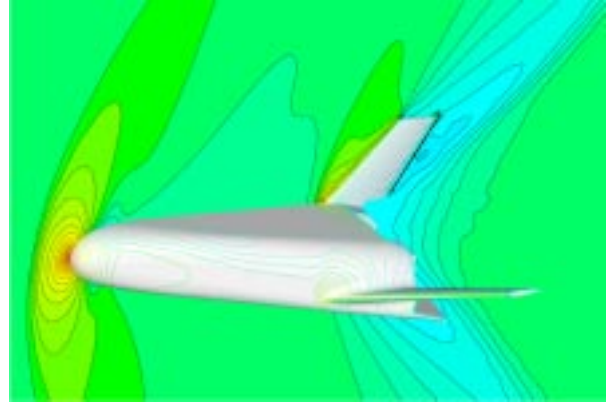

Figure 15. Color contours of C_p from FELISA for RLV 0023 configuration. $Mach = 1.15$, $\alpha = 2.5^\circ$.

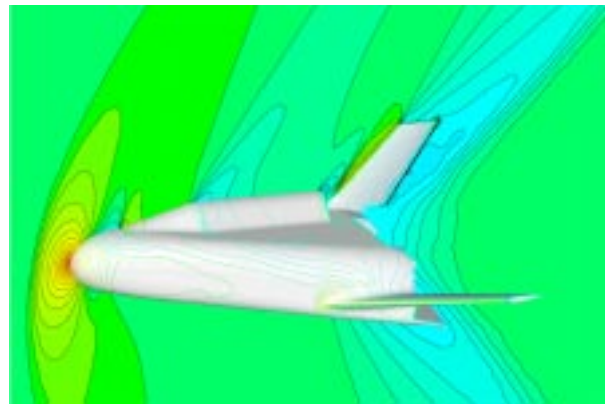

Figure 16. Color contours of C_p from FELISA for RLV 0023 with payload bay pooch configuration. $Mach = 1.15$, $\alpha = 2.5^\circ$.

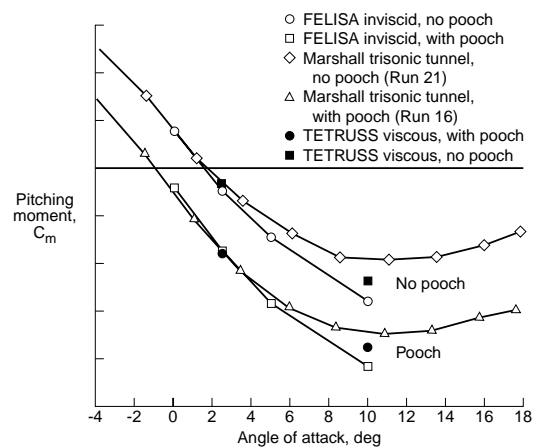

Figure 17. 0023 pooch vs. no pooch transonic pitching moment.

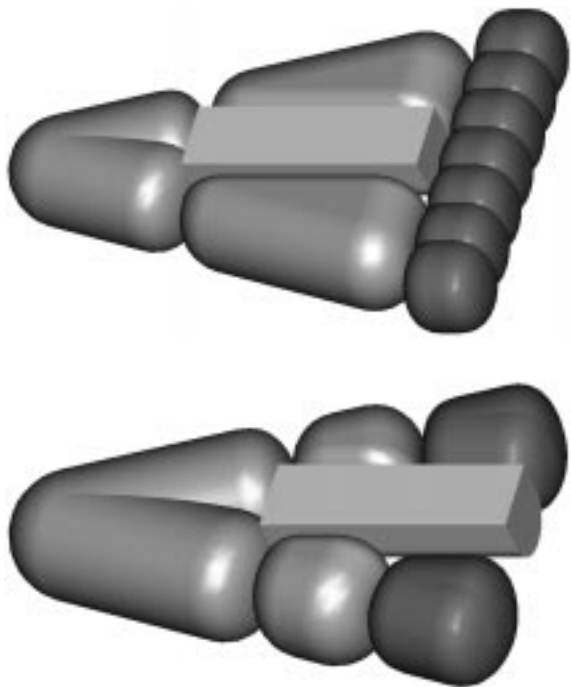

Figure 18. LOX aft concepts with internal payload bays.

LOX, over 70% of the vehicle weight on launch, has to be supported by the intertank and the LH2 tanks. The LOX aft configuration locates the high loads of the LOX close to the thrust structure, and significantly reduces the structure of the LH2 tanks and intertank. (The reduction in LH2 tank weight achieved is dependent on operating pressure.) One of the issues associated with this approach is the resultant aft cg during ascent, and its potential impact on the control effectiveness of the thrust vectoring engine. LaRC's thrust vectoring engine database was used with 3-DOF POST to simulate a trimmed ascent trajectory. It was shown that trim throughout ascent would remain possible with the aft cg using no more than 50% of the total thrust vectoring authority. Thus 50% of the vectoring authority was available for control. At the time, the LOX aft concepts would remain constrained to consider internal payload bays only, to enable more direct comparison to the LMSW baseline shapes. However, as shown in Figure 18 one of the results of this restriction is an increase in the number of LH2 tanks required to package around the payload bay. Thus the configurations incurred an increase in the structural weight. (ref 3) The LOX aft concept was further refined by LMSW, and combined with a single LH2 tank and a 100% pooched payload bay, to design one of the follow-on configurations, the LMSW 0028 shown in Figure 19. The configuration was later eliminated by LMSW due to the estimated weight increase in the propulsion system resulting from LOX aft. (The LOX head pressure at the turbine inlet is lower for a LOX

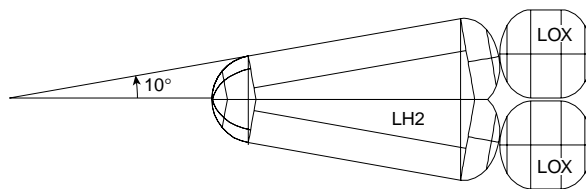

Figure 19. LOX aft concept 0028.

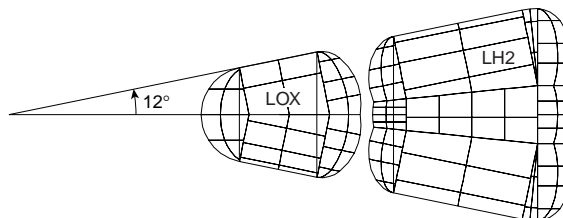

Figure 20. High Fineness LOX Forward configuration, HFLF.

aft configuration compared to a LOX forward configuration for the same ullage pressure, requiring potential modification to the propulsion system.) It was uncertain at the time whether or not LOX aft would be a positive trade result.

In addition to being a LOX aft configuration, the LMSW 0028 has a significantly higher fineness ratio, or smaller planform included half angle of 10°, than previously allowed for consideration in the lifting body design space. The higher fineness concept was carried further with the high fineness LOX forward (HFLF) configuration, shown in Figure 20. The objective for the higher fineness configurations were to shift the dry weight cg forward, compared to lower fineness configurations, to reduce the overall structural weight for a trimmed configuration; and to reduce ascent drag losses. It was estimated that the HFLF would provide a reduction in dry weight, but the magnitude of the weight reduction was not viewed as significant enough to

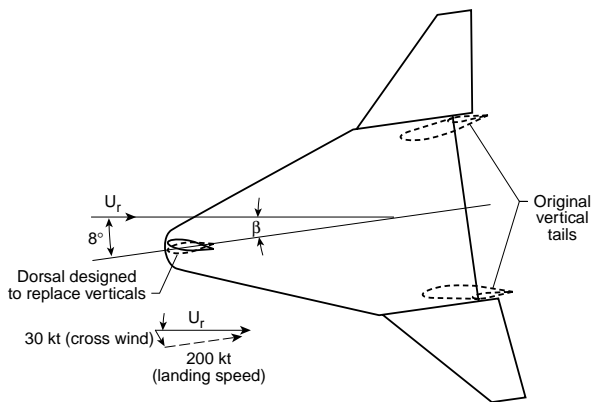

Figure 21. Dorsal concept.

warrant a departure from the existing database of lower fineness lifting body configurations.

One of the concepts explored to specifically address the cg location issue included a dorsal fin, designed to eliminate the vertical tails. The dorsal, shown in Figure 21, was sized to enable landing in a 30 knot cross wind. The cg shift of slightly more than 1% and a vehicle weight reduction of slightly over 2% attained by replacing the vertical tails with a dorsal fin, were significant improvements. Feasibility of the dorsal concept for control in a cross wind landing was shown through a preliminary control design and analysis. However, the aerodynamic risk was considered to be too high. Not only was the vehicle directionally statically unstable, but because of the lifting body, the longitudinal aerodynamics would most likely be significantly influenced by the presence and deflection of the dorsal. As a result, the dorsal concept was eliminated from further consideration. The concept of a control-stabilized vehicle, as opposed to a statically stable vehicle, however, could be adopted for vertical tail sizing, as well. This would allow for some reduction in the vertical tail weight. Along these lines, the latest VentureStar™ concept (ref 2) incorporates smaller tip fins for lateral-directional control instead of large vertical tails.

One of the most beneficial performance trades for increasing payload to orbit, applicable to any of the VentureStar™ concepts, is the trade on vehicle average mixture ratio. (ref 5) In other words, the ratio of LOX to LH2, and the corresponding tank sizes, packaged in the vehicle can be optimized to achieve a maximum payload to orbit for a given vehicle size. The baseline VentureStar™ concepts have a ratio of LOX to LH2 of 6 based on weight. Thus, although the mixture ratio of the engine can be variable during the ascent, the average mixture ratio must be maintained at 6. Trade study results show that the payload to orbit increases as the mixture ratio is increased, up to a mixture ratio of 6.5. This maximum occurs when the difference between the gain in payload due to an increase in vehicle bulk density (at increased mixture ratios), and the loss in payload due to a reduction in the average engine specific impulse over the trajectory, is greatest. At a vehicle average mixture ratio of 6.5, the vehicle dry weight is approximately 2% less than the same size vehicle with the baseline mixture ratio of 6. Thus a significant increase in payload mass results. (ref 5) Other trades on ascent trajectories have been made including determining the sensitivity of payload to orbit as a function of mixture ratio profile, lifting versus non-lifting trajectories, normal and axial force constraints, trimmed versus untrimmed trajectories, and vehicle lift-off thrust to weight. Results are reported in Reference 5.

Another of the challenges in the maturation of the VentureStar™ vehicle is in the development of a control strategy. Ascent control may be achieved through some combination of aerospike engine thrust vectoring and aerodynamic surface control, although engine thrust vectoring is baselined. (If control surfaces are used, they must be structurally sized to take the higher ascent loads as compared to entry loads.) Entry control, which was the primary focus of the LaRC work (ref 6), is achieved through a combination of the reaction control system (RCS) at the high Mach numbers and aerodynamic control surface mixing as control authority increases at lower altitude. The control strategy has to be developed at many points across the flight regime due to the wide variation of aerodynamic forces on entry as noted previously. Sensitivities to control surface mixing strategies, cg location and winds were investigated. The hypersonic trim and the resultant availability of control authority, as described above, and the subsonic longitudinal stability have proven to be the most challenging. (ref 6)

One of the objectives for the entry control system design is to utilize the aerodynamic surfaces as early in the trajectory as possible to minimize the RCS fuel requirements. An alternate reverse-aileron control strategy is proposed either in full or partial implementation, to reduce RCS propellant requirements. The strategy utilizes the vehicle's natural tendency for reverse roll as control. That is, if the requirement is to roll to the right, the ailerons initially roll the vehicle left, generating sideslip. This sideslip combined with the strong dihedral effect will then roll the vehicle to the right. The net effect is a reduction in the RCS required to maneuver the vehicle during entry. (ref 6)

SUMMARY

A number of configuration modifications have been identified to significantly reduce the weight of the VentureStar™ vehicle and improve its flyability. In addition, ascent trajectory strategies applicable to many of the configurations have been developed to enable additional payload to orbit for a given vehicle size. Control strategies and sensitivities have been defined to assist in further vehicle refinement, and to identify potential RCS fuel reduction approaches. Many concepts and results have been incorporated into the LMSW designs in varying forms.

ACKNOWLEDGEMENTS

Thank you to the members of the NASA Langley Research Center technical team for their contribution to the VentureStar™ configuration work and to this paper: Karen Bibb, Phil Calhoun, John Dorsey, John Korte, Roger Lepsch, Carl Martin, Mark McMillin, Matt Rhode, Bill Scallion, Paul Tartabini, Robin Tutterow, Chauncy Wu,

Kathryn Wurster, LaRC, Jeff Cerro, Chris Cruz, Garry Qualls, Jim Robinson, NYMA, Paresh Parikh, Paragon Research. Thank you to Charles Miller, Steve Scotti, Dave Throckmorton, and Del Freeman, LaRC, and Steve Cook, MSFC, for their support and guidance in this activity. Thank you to Rick Ryan, MSFC, for managing and providing insight in our concept brainstorming work. Thank you to the LMSW VentureStar™ team for the opportunity to work with them on the VentureStar™, and to John Vinson, LMSW, in particular for collaboration on the concept brainstorming work. Thank you to Anne Costa for her work on preparing this paper for publication.

REFERENCES

1. Powell, R.W., Cook, S.A., Lockwood, M.K., "The Road from the NASA Access to Space Study to a Reusable Launch Vehicle," IAF-98-V.4.02, 1998.
2. Dornheim, M.A., "Engineers Anticipated X-33 Tank Failure," Aviation Week and Space Technology, 11/15/1999.
3. Dorsey, J., Meyers, D. and Martin, C., "Reusable Launch Vehicle Tank/Intertank Sizing Trade Study," AIAA Paper 2000-1043, 2000.
4. Korte, J., "Parametric Model of an Aerospike Rocket engine," AIAA 2000-1044, 2000.
5. Tartabini, P., Lepsch, R., Korte, J., Wurster, K., "A Multidisciplinary Performance Analysis of a Lifting-Body Single-Stage-to-Orbit Vehicle," AIAA 2000-1045, 2000.
6. Calhoun, P., "Entry Flight Controls Analysis for VentureStar™," AIAA 2000-1046, 2000.
7. Lepsch, R., Rhode, M., Cruz, C., Unal, R., "VentureStar™ Wing Shape Optimization Using Response Surface Methods," AIAA 2000-1047, 2000.
8. Lepsch, R. A., Jr., Stanley, D. O., Cruz, C. I., and Morris, S. J., Jr., "Utilizing Air-Turbo-rocket and Rocket Propulsion for a Single-Stage-to-Orbit Vehicle," *Journal of Spacecraft and Rockets*, Vol. 28, No. 5, 1991, pp. 560-566.
9. Bonner, E., Clever, W., and Dunn, K.: "Aerodynamic Preliminary Analysis System II, Part I-Theory," NASA CR-182076, April 1991.
10. Brauer, G.L, Cornick, D.E., and Stevenson, T., "Capabilities and Applications of the Program to Optimize Simulated Trajectories (POST)," "NASA CR-2770, February, 1977.
11. Engelund, W.C., Ware, G.W., "Aerodynamic Predictions and Experimental Results for an Advanced Manned Launch System Orbiter Configuration," AIAA 93-1020, February, 1993.
12. Cruz, C.I, Ware, G.M., "Predicted Aerodynamic Characteristics for the HL-20 Lifting Body Using the Aerodynamic preliminary Analysis System (APAS)." AIAA 92-3941, July 1992.
13. Lockwood, M.K., McMillin, M.L., Tartabini, P.V., Wurster, K.E., Lepsch, R.A., Cruz, C.I., Queen, E., Striepe, S.A., Bibb, K.L., Hamilton, H., Rhode, M.N., Korte, J.J., Dorsey, J.T., Cerro, J.A., Martin, C., Rivers, K., Smith, R., Wu, C., "NASA Langley Methods Validation, Calibration and Results, and Application to RLV Development in 1998," Internal LaRC Report, January 1998.
14. Peiro, J., Peraire, J., and Morgan, K., "FELISA System Reference Manual and User's Guide," Tech. Rep., University College Swansea Report, 1993.
15. Frink, N.T., Pirzadeh, S., and Parikh, P., "Grid Software System for Solving Complex Aerodynamic Problems," "NASA CP 3291, May 1995.
16. Engle C.D., Praharaj S.C., MINIVER upgrade for the AVID system, vol. I: LANMIN User's Manual, NASA CR-172212, 1983.
17. Grace, A., Laub, A.J., Little, J.N., Thompson, C. M., "Control System Toolbox User's Guide", The Mathworks, Inc., July 1992.
18. Documentation for I-DEAS © 1999 Structural Dynamics Research Corporation can be located at www.sdrc.com/nav/software-services/ideas, as accessed January 7, 2000.
19. Dorsey, J.T., Wu, K.C., Rivers, K., Martin, C., Smith, R., "Airframe Integration Trade Studies for a Reusable Launch Vehicle," presented at the 1999 Space Technology & Applications International forum Conference on Next Generation Launch Vehicles, Albuquerque, NM.
20. Paragon Research Associates, Inc., "Computational Support for Reusable Launch Vehicle Studies," Final Report for work done under Prime Contract NAS1-96013, Subcontract ADF 98-030, June 21, 1999.