

LAMB WAVE RESPONSE OF FATIGUED COMPOSITE SAMPLES

Review of Progress in Quantitative Nondestructive Evaluation, Vol 13B (1994)
pp. 1261-1266

Michael D. Seale and Barry T. Smith
Departments of Physics and Applied Science
The College of William and Mary
Williamsburg, VA 23187

William H. Prosser
Mail Stop 231
NASA Langley Research Center
Hampton, VA 23681

John E. Masters
Lockheed Engineering and Sciences
144 Research Drive
Hampton, VA 23666

INTRODUCTION

Composite materials are being more widely used today by aerospace, automotive, sports equipment, and a number of other commercial industries because of their advantages over conventional metals. Composites have a high strength-to-weight ratio and can be constructed to meet specific design needs.

Composite structures are already in use in secondary parts of the Douglas MD-11 and are planned to be used in the new MD-12X. Plans also exist for their use in primary and secondary structures on the Boeing 777. Douglas' proposed MD-XX may also incorporate composite materials into primary structures such as the wings and tail. Use of composites in these structures offers weight savings, corrosion resistance, and improved aerodynamics [1]. Additionally, composites have been used to repair cracks in many B-1Bs where traditional repair techniques were not very effective. Plans have also been made to reinforce all of the remaining B-1s with composite materials [2].

Verification of the structural integrity of composite components is needed to insure safe operation of these aerospace vehicles. One aspect of the use of these composites is their response to fatigue [3,4]. To track this progression of fatigue in aerospace structures, a convenient method to nondestructively monitor this damage needs to be developed. Traditional NDE techniques used on metals are not easily adaptable to composites due to the inhomogeneous and anisotropic nature of these materials. Finding an effective means of nondestructively monitoring fatigue damage is extremely important to the safety and reliability of such structures.

Lamb waves offer one method of evaluating these composite materials [5,6]. As a material is fatigued, the modulus degrades. Since the Lamb wave velocity can be related to the modulus of the material, an effective tool can be developed to monitor fatigue damage in composites by measuring the velocity of these waves.

In this work, preliminary studies have been conducted which monitor fatigue damage in composite samples using strain gage measurements as well as Lamb wave velocity measurements. A description of the test samples is followed by the results of two different measurements of Lamb wave velocity. The first technique is a contact measurement done at a single frequency, while the second involves an immersion study of Lamb waves in which dispersion curves are obtained. The results of the Lamb wave monitoring of fatigue damage is compared to the damage progression measured by strain gages. The final section discusses the results and conclusions.

SAMPLES

The composite samples studied were AS-4/3501-6 graphite/epoxy with a stacking sequence of $[0/90_3]_S$. Two 12 x 15 inch plates were manufactured and C-scanned prior to being cut into specimens to check for any abnormalities. The plates were then cut into 11 x 1.5 inch coupons. Strain gages (one axial, one transverse) and fiberglass tabs were attached to each sample. Of the samples, two were loaded quasi-statically to failure to obtain Young's Modulus, Poisson's Ratio, and ultimate strength.

In this study, specimens have been subjected to tension-tension fatigue. The samples were fatigued at a frequency of 10 Hz and at an R value of 0.3 with an upper load value of 160 MPa. Some samples were fatigued to a terminal cycle value while others were successively raised to higher fatigue cycle values. The velocity of the lowest order symmetric Lamb mode was measured and the modulus obtained from strain gage measurements both before and after each cyclic loading. The samples raised to successive cycle values were removed from the load frame at intermediate values of fatigue cycles in order to make the contact measurements .

CONTACT MEASUREMENT

Lamb wave modes can be generated by placing a longitudinal wave contact type transducer on a plate structure. Mode conversion of a part of the wave to shear waves and subsequent mixing of SV and P waves form Lamb wave modes. A Lamb wave was generated by using a 2 cycle, 500 kHz sine wave to excite the sending transducer. The signal was received at various positions, digitized, and the waveforms saved on a computer (Figure 1). Both the sending and receiving transducers were broadband contact longitudinal wave transducers with a nominal center frequency of 1 MHz and a diameter of 0.5 inches. A gel was used as a couplant between the transducers and the plate.

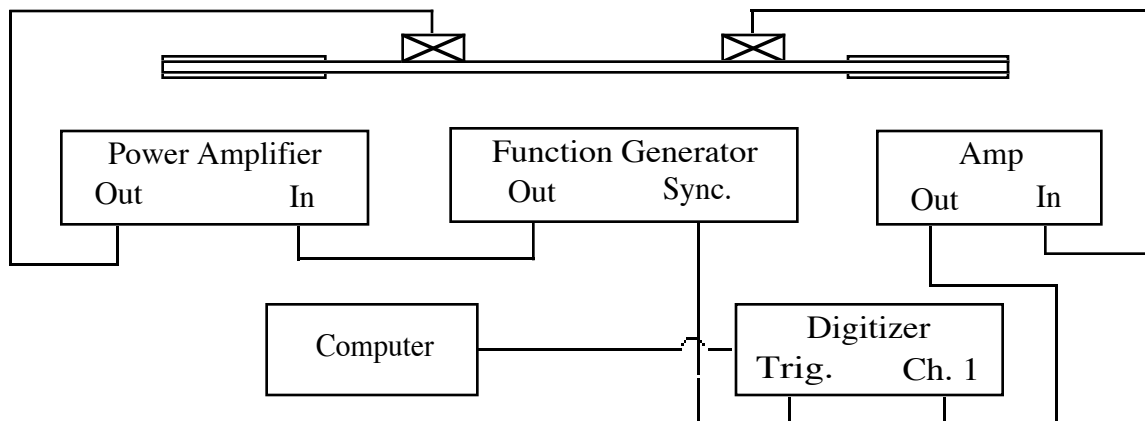

Figure 1. Experimental arrangement for contact measurement.

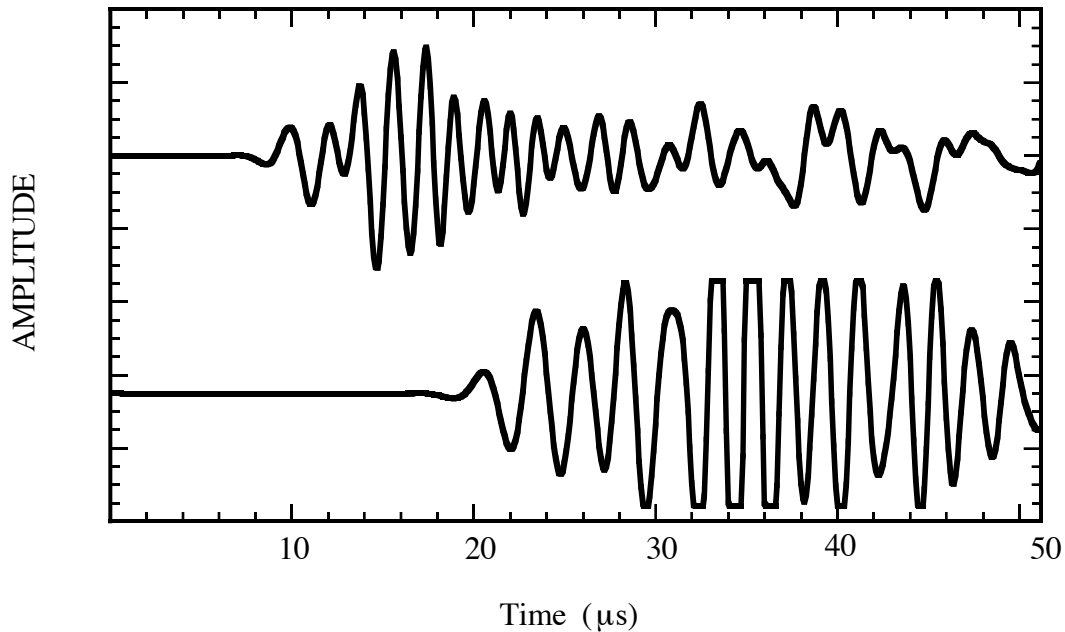

Figure 2. Signals from transducers separated by 5.5 cm.

The time differences were measured by imposing a computational delay on the first signal to overlap the signals received at greater distances (Figure 2). The distances were measured to an accuracy of 0.01 cm using a sonic ranger. A least-squares fit was then performed to obtain the velocity from a plot of time and distance.

CONTACT ANALYSIS

As the samples underwent increasing amounts of fatigue, an increasing number of cracks in the 90-degree plies was observed under a microscope. These cracks degrade the modulus. For isotropic plates the Lamb wave velocity depends on the square root of the elastic modulus for the lowest order symmetric mode [7]. For convenience the square of the velocity was chosen to plot against the number of fatigue cycles. The composite samples exhibited a decrease in the square of the velocity as the modulus degraded due to increasing fatigue (figure 3).

In figure 3, the velocity was normalized to the velocity measured before fatiguing. The normalized modulus was obtained in a similar manner. The velocity error bars are an estimate of the total error due to the uncertainty in the distance and time measurements. For the data in figure 3, the same sample was subjected to increasing fatigue cycles. For the case of different specimens fatigued to various terminal cycle values, the overall plot revealed no discernible trend. This result was due to the material variations across the manufactured plates, which had appreciable levels of porosity.

IMMERSION MEASUREMENT

In addition to the contact measurements which were done at a single frequency, an immersion method (figure 4), detailed elsewhere [8], was used to obtain dispersion curves for two different samples. Two samples were examined: one with no load history and a

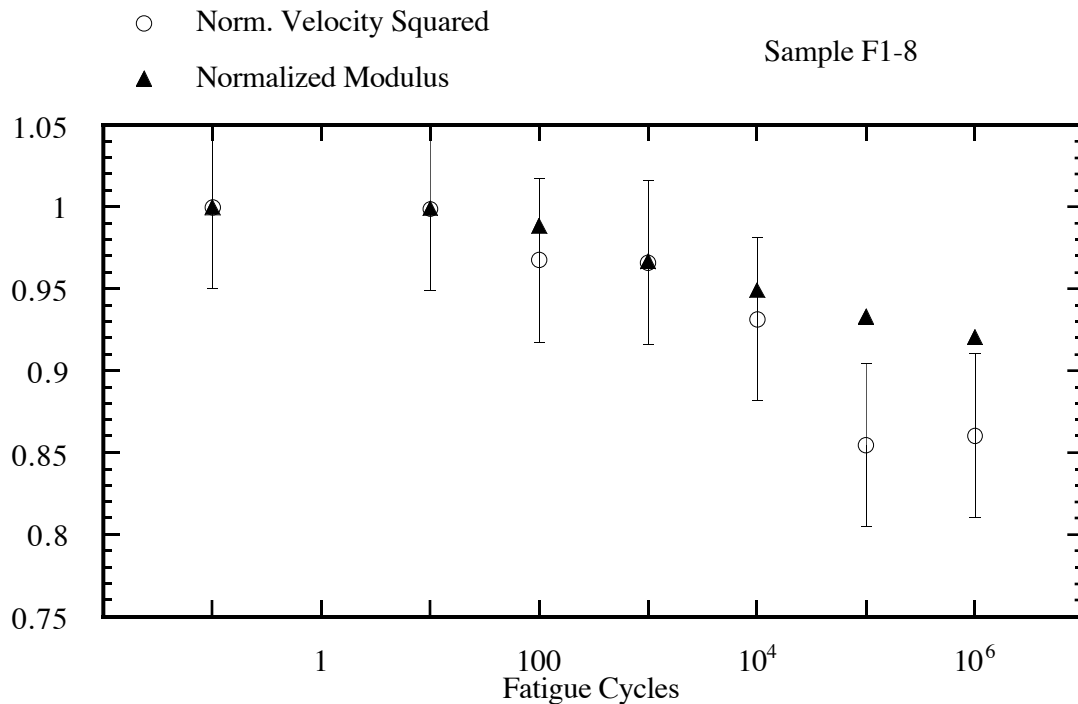

Figure 3. Normalized velocity squared vs. fatigue cycles for sample F1-8.

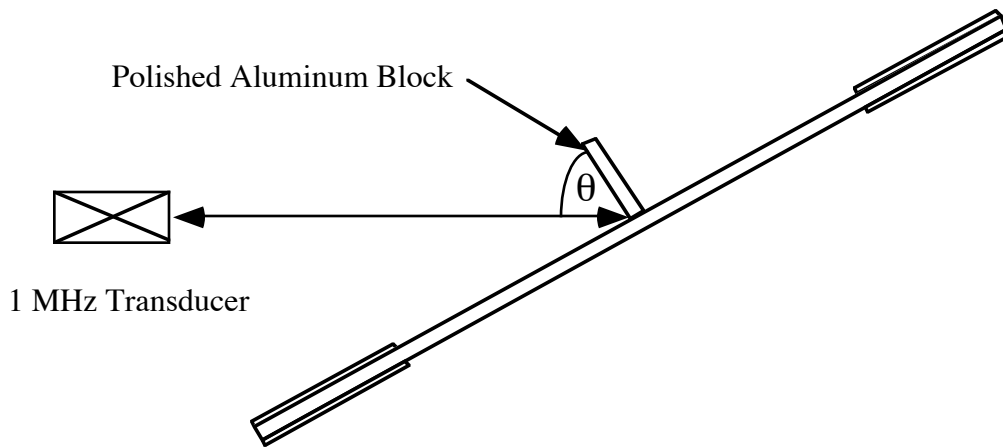

Figure 4. Experimental set-up for immersion technique.

second sample that had undergone one million fatigue cycles. In this method, an aluminum block serves as a corner reflector for the input pulse. When a Lamb wave is excited in the plate, part of the total energy is converted to a propagating Lamb wave. Due to this loss of energy, a minimum in the frequency spectrum of the reflected signal corresponds to the frequency at which a lamb wave mode is propagating. In this experiment, the specimen was rotated from 0.4 to 60 degrees in steps of 0.4 degrees.

The reflected waveform at each angle was saved for later analysis of the frequency content (figure 5). After determining the frequency of the minimum for each angle, the velocity (from Snell's Law) versus the frequency times thickness was then plotted to obtain the dispersion curve.

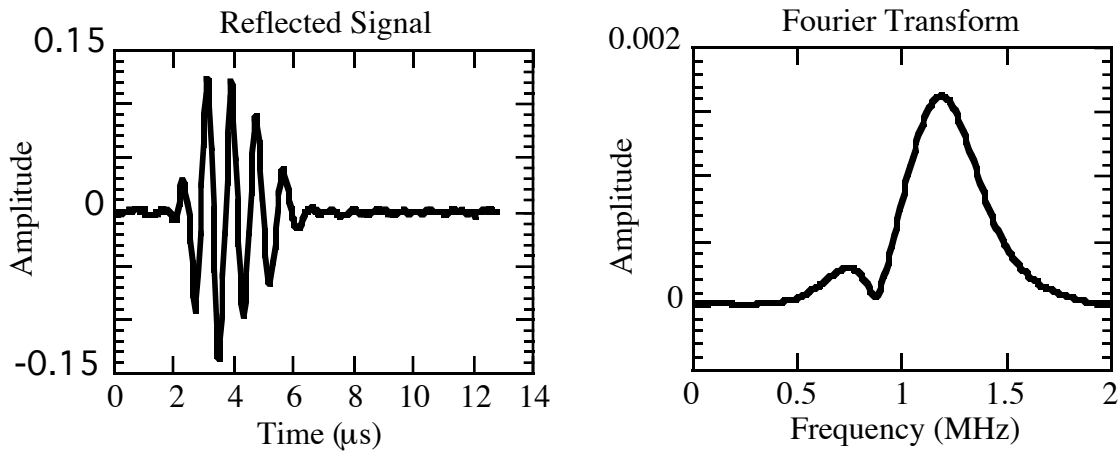

Figure 5. Reflected signal and Fourier Transform showing minimum.

IMMERSION ANALYSIS

The dispersion curves for the two lowest order modes are significantly separated for the two samples (figure 6). The curves have a 7 percent difference in velocity for the symmetric mode. This is in good agreement with the contact result for the same sample, which had a 7.3 percent relative decrease in velocity after one million fatigue cycles.

The A_0 mode velocity variation is much less than that of the S_0 mode. This can be understood by examining how the velocity relates to the modulus. The velocity changes as the square root of the modulus for the symmetric mode, but as the fourth root of the modulus for the antisymmetric mode [7]. Therefore, the A_0 mode velocity will change less than the S_0 mode velocity for a given decrease in modulus.

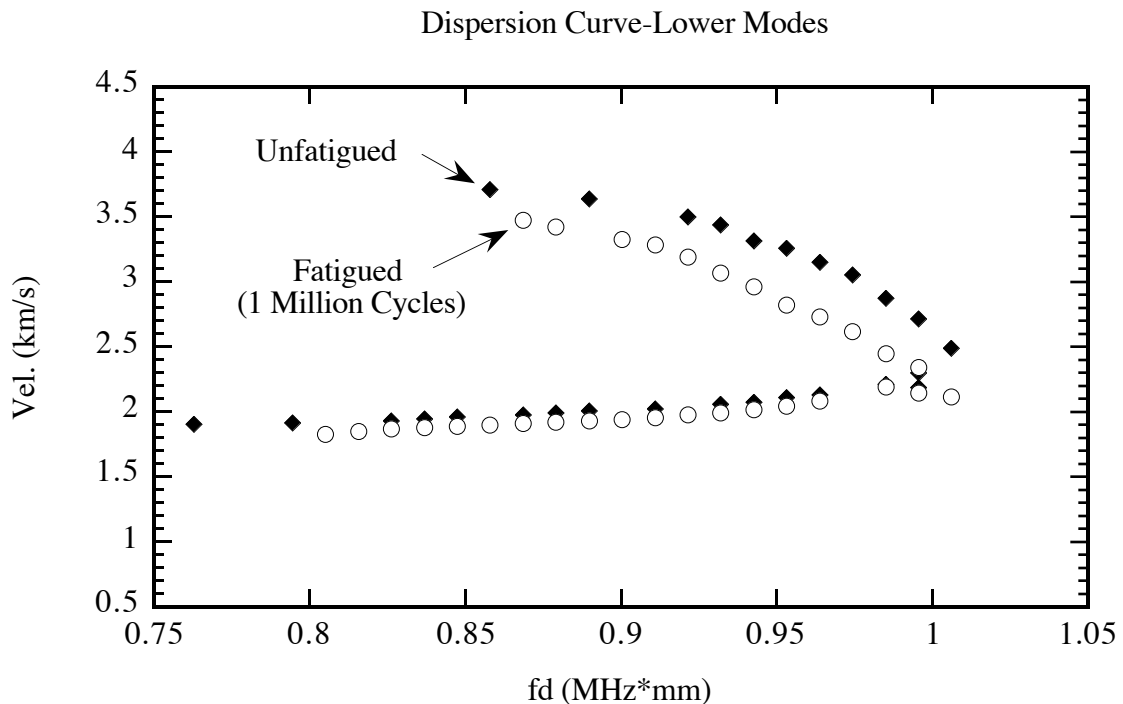

Figure 6. Dispersion curve for the lower modes showing the change in velocity for a fatigued composite sample.

DISCUSSION

Presented above are the results of two techniques for determining the Lamb wave velocity in composites. The results of the contact measurement showed that the change in modulus as measured using strain gages and change in velocity squared follow the same general trend. A change in velocity due to the modulus degradation was also seen in the results of the immersion measurement.

The Lamb wave velocity measurements in this study were conducted at long wavelengths. This was done for several reasons. First, if a long wavelength limit is assumed, the composite can be treated as homogeneous. Second, there is very little dispersion of the lowest order symmetric mode in the frequency range where the contact measurements were conducted. Finally, global information about the integrity of the material can be obtained.

It has been noted by other authors that strain gages only measure a local change in modulus and do not measure a global change in the specimen [4]. Since the strain gages used in this study had a gauge length of 1/4 inch, they may not give an accurate account of damage throughout the entire plate. This would be especially true at the lower fatigue levels where very few cracks were observed in the samples. Thus, a Lamb wave technique at low frequencies used to track the modulus as a function of fatigue history may provide improved global interrogation over the propagation length of the wave.

In the future, samples with other stacking sequences, as well as woven and braided specimens, will be investigated.

ACKNOWLEDGEMENTS

This work was supported in part by NASA Grant NAG-1-1063 and NASA Task Assignment NAS1-19656.

REFERENCES

1. D. Stover, senior editor, "Composites use increases on new commercial transports...", *Advanced Composites*, Vol. 6, No. 5, Sept./Oct. 1991, pp. 30-40.
2. Composites News, "Boron/epoxy system to repair entire B-1 fleet," *Advanced Composites*, Vol. 6, No. 5, Sept./Oct. 1991, pp. 18-20.
3. O'Brien, T. K., Rigamonti, M., and Zanotti, C., "Tension Fatigue Analysis and Life Prediction for Composite Laminates," *Int. J. Fatigue*, Vol. 11, No. 6, 1989, pp. 379-393.
4. Charewicz, A. and Daniel, I. M., "Damage Mechanisms and Accumulation in Graphite/Epoxy Laminates," *Composite Materials: Fatigue and Fracture*, ASTM STP 907, H. T. Hahn, Ed., American Society for Testing and Materials, Philadelphia, 1986, pp. 274-297.
5. Guo, Ningqun and Cawley, Peter, "Lamb Waves for the NDE of Composite Laminates," *Review of Progress in QNDE*, ed. D.O. Thompson and D.E. Chimenti, Vol. 11, Plenum Press, New York, 1992, pp. 1443-1450.
6. Tang, B. and Henneke, II, E. G., "Lamb-Wave Monitoring of Axial Stiffness Reduction of Laminated Composite Plates," *Materials Evaluation*, 47, August 1989, pp. 928-934.
7. Prosser, William H., "The Propagation Characteristics of the Plate Modes of Acoustic Emission Waves in Thin Aluminum Plates and Thin Graphite/Epoxy Composite Plates and Tubes," Ph.D. Dissertation, The Johns Hopkins University, November, 1991, pp. 60-117.

8. Balasubramaniam, Krishnan and Rose, Joseph L., "Physically Based Dispersion Curve Feature Analysis in the NDE of Composites," *Res. Nondestr Eval* (1991) 3, Springer-Verlag New York Inc., pp. 41-67.