

REPORT DOCUMENTATION PAGE			Form Approved OMB No. 0704-0188	
Public reporting burden for this collection of information is estimated to average 1 hour per response, including the time for reviewing instructions, searching existing data sources, gathering and maintaining the data needed, and completing and reviewing the collection of information. Send comments regarding this burden estimate or any other aspect of this collection of information, including suggestions for reducing this burden, to Washington Headquarters Services, Directorate for Information Operations and Reports, 1215 Jefferson Davis Highway, Suite 1204, Arlington, VA 22202-4302, and to the Office of Management and Budget, Paperwork Reduction Project (0704-0188), Washington, DC 20503.				
1. AGENCY USE ONLY (Leave blank)	2. REPORT DATE October 1992	3. REPORT TYPE AND DATES COVERED Technical Paper		
4. TITLE AND SUBTITLE Laboratory Study of Effects of Sonic Boom Shaping on Subjective Loudness and Acceptability			5. FUNDING NUMBERS WU 537-03-21-03	
6. AUTHOR(S) Jack D. Leatherwood and Brenda M. Sullivan				
7. PERFORMING ORGANIZATION NAME(S) AND ADDRESS(ES) NASA Langley Research Center Hampton, VA 23681-0001			8. PERFORMING ORGANIZATION REPORT NUMBER L-17050	
9. SPONSORING/MONITORING AGENCY NAME(S) AND ADDRESS(ES) National Aeronautics and Space Administration Washington, DC 20546-0001			10. SPONSORING/MONITORING AGENCY REPORT NUMBER NASA TP-3269	
11. SUPPLEMENTARY NOTES Leatherwood: Langley Research Center, Hampton, VA; Sullivan: Lockheed Engineering & Sciences Co., Hampton, VA.				
12a. DISTRIBUTION/AVAILABILITY STATEMENT Unclassified-Unlimited Subject Category 71			12b. DISTRIBUTION CODE	
13. ABSTRACT (Maximum 200 words) A laboratory study was conducted to determine the effects of sonic boom signature shaping on subjective loudness and acceptability. The study utilized the sonic boom simulator at the Langley Research Center. A wide range of symmetrical, front-shock-minimized signature shapes were investigated together with a limited number of asymmetrical signatures. Subjective loudness judgments were obtained from 60 test subjects by using an 11-point numerical category scale. Acceptability judgments were obtained using the method of constant stimuli. Results were used to assess the relative predictive ability of several noise metrics, determine the loudness benefits of detailed boom shaping, and derive laboratory sonic boom acceptability criteria. These results indicated that the A-weighted sound exposure level, the Stevens Mark VII Perceived Level, and the Zwicker Loudness Level metrics all performed well. Significant reductions in loudness were obtained by increasing front-shock rise time and/or decreasing front-shock overpressure of the front-shock-minimized signatures. In addition, the asymmetrical signatures were rated to be slightly quieter than the symmetrical front-shock-minimized signatures of equal A-weighted sound exposure level. However, this result was based on a limited number of asymmetric signatures. The comparison of laboratory acceptability results with acceptability data obtained in more realistic situations also indicated good agreement.				
14. SUBJECT TERMS Sonic boom; Subjective loudness; Acceptability; Sonic boom simulator; Signature shaping			15. NUMBER OF PAGES 26	
			16. PRICE CODE A03	
17. SECURITY CLASSIFICATION OF REPORT Unclassified	18. SECURITY CLASSIFICATION OF THIS PAGE Unclassified	19. SECURITY CLASSIFICATION OF ABSTRACT	20. LIMITATION OF ABSTRACT	

Abstract

A laboratory study was conducted to determine the effects of sonic boom signature shaping on subjective loudness and acceptability. The study utilized the sonic boom simulator at the Langley Research Center. A wide range of symmetrical, front-shock-minimized signature shapes were investigated together with a limited number of asymmetrical signatures. Subjective loudness judgments were obtained from 60 test subjects by using an 11-point numerical category scale. Acceptability judgments were obtained using the method of constant stimuli. Results were used to assess the relative predictive ability of several noise metrics, determine the loudness benefits of detailed boom shaping, and derive laboratory sonic boom acceptability criteria. These results indicated that the A-weighted sound exposure level, the Stevens Mark VII Perceived Level, and the Zwicker Loudness Level metrics all performed well. Significant reductions in loudness were obtained by increasing front-shock rise time and/or decreasing front-shock overpressure of the front-shock-minimized signatures. In addition, the asymmetrical signatures were rated to be slightly quieter than the symmetrical front-shock-minimized signatures of equal A-weighted sound exposure levels. However, this result was based on a limited number of asymmetric signatures. The comparison of laboratory acceptability results with acceptability data obtained in more realistic situations also indicated good agreement.

Introduction

The economic viability of proposed advanced High-Speed Civil Transport (HSCT) aircraft could be significantly enhanced if these aircraft were permitted to fly over land at supersonic speeds. To accomplish this, however, would require aircraft configurations based upon “minimum-boom” design considerations. Minimum-boom design involves tailoring the lift and volume distributions of the aircraft to minimize the loudness of the sonic boom signature, reduce the subjective startle effects, and lessen indoor effects such as wall and window vibration and rattle. Sonic boom minimization generally involves detailed “shaping” of a boom signature in a way that reduces the high-frequency components of the signature as well as minimizes the peak overpressure effects. Both of these steps increase boom acceptability.

The potential benefits of sonic boom shaping are discussed in references 1 and 2, which describe the results of paired comparison subjective tests to assess the relative loudness of N-wave booms defined by various combinations of rise time, duration, and peak overpressure. Results from these studies show that, for constant peak overpressure, substantial reductions in subjective loudness can be achieved by increasing the rise time of the front and rear shocks. Other studies (refs. 3 and 4) suggest that boom loudness can be reduced by more detailed shaping of the signature. This approach usually involves replac-

ing the N-wave signatures with signatures that have achieved peak overpressure in two pressure steps instead of one. This method is referred to as front-shock minimization (FSM). The procedure entails decreasing the strength associated with the initial pressure rise (front shock) and then allowing a slower pressure rise until it reaches maximum overpressure. Signatures shaped in this manner would contain significantly less high-frequency energy than those of N-waves of equivalent peak overpressure.

The primary objectives of this paper are to quantify the effects of boom shaping via FSM on subjective loudness, assess the relative ability of several noise metrics to predict the loudness of shaped sonic booms, conduct preliminary investigations of the effects of signature asymmetry on subjective loudness, and develop laboratory acceptability criteria and comparison of these with criteria specifications derived under more realistic conditions. These objectives were accomplished by eliciting subjective loudness responses from a group of 60 test subjects who listened to and rated a wide range of shaped booms. The shaped booms included symmetrical, front-shock-minimized signatures covering a wide range of FSM parameters and several asymmetrical signatures corresponding to candidate “low-boom” aircraft designs. All the signatures represented booms that may be heard outdoors. No attempt was made to modify the signatures to

represent those that may be heard indoors. The term symmetrical, within the context of this paper, means that the compression and rarefaction phases of a signature are nominally inverse mirror images of each other.

The FSM parameters include the rise time of the front shock, the rise time associated with the secondary shock rise in pressure (i.e., the slower rise from the front-shock overpressure to peak overpressure), and the ratio of front-shock overpressure to peak overpressure. Each boom was evaluated by the test subject group using the numerical category scaling technique. The test facility used was the Langley Research Center sonic boom simulator. Direct evaluations of boom loudness acceptability also were obtained for a small subset of the total stimuli set. These evaluations provided a basis for defining a preliminary laboratory acceptability criterion and for comparing laboratory results with results obtained in more realistic situations.

Symbols

L_{AE}	A-weighted sound exposure level, dB
L_{CE}	C-weighted sound exposure level, dB
L_{UE}	unweighted sound exposure level, dB
L_{XE}	sound exposure level for frequency weighting X , dB
LLZ	Zwicker Loudness Level, dB
PL	Stevens Mark VII Perceived Level, dB
P	probability
P_{ref}	reference sound pressure, 0.00002 Pa (0.41797×10^{-6} lbf/ft ²)
$p_X(t)$	instantaneous time-varying X -weighted sound pressure, lbf/ft ²
t_0	reference time of 1 sec for sound exposure level
$t_{1,2}$	effective beginning and ending times, respectively, of boom signature
X	frequency weighting (A-weighted, C-weighted, or unweighted) for sound exposure level, dB
ΔP_f	front-shock overpressure, lbf/ft ²
ΔP_{max}	peak overpressure level, lbf/ft ²
τ_1	front-shock rise time, msec
τ_2	secondary rise time, msec

Experimental Method

Sonic Boom Simulator

The experimental apparatus used in this study was the Langley Research Center sonic boom simulator. Construction details, performance capabilities, and operating procedures of the simulator are given in reference 2. The simulator, shown in figure 1, is a person-rated, airtight, loudspeaker-driven booth capable of accurately reproducing user-specified sonic boom waveforms at peak sound pressure levels up to approximately 138 to 139 dB. Input waveforms were computer generated and “predistorted” to compensate for nonuniformities in the frequency response characteristics of the booth and sound reproduction system. Predistortion was accomplished by the use of a digital broadband equalization filter (ref. 5).

Test Subjects

Sixty test subjects (39 females and 21 males), who were obtained from a subject pool of local residents, were used in this study. The ages of the test subjects ranged from 18 years to 60 years; the median age of these subjects was 33.5 years. All subjects were required to undergo audiometric screening prior to the test to ensure that they had normal hearing.

Experimental Design

Each subject participated in two separate experiments that differed in the scaling method used and in the number of stimuli presented. In the first experiment, the subjects were required to make loudness judgments of all test stimuli by using a numerical category scale. This scale permitted direct comparison of the subjective loudness scores between individual boom signatures, facilitated statistical analysis of the test results, and allowed direct evaluation of boom-shaping effects. Note, however, that these loudness judgments cannot be interpreted in terms of absolute loudness.

In the second experiment, in which a subset of the boom stimuli was utilized, the subjects were required to simply indicate whether or not a boom was acceptable. The resulting ratings then were used to determine approximate acceptability thresholds within the simulator. Details of the stimuli and scaling methods are described in the following sections.

Test stimuli for first experiment. The set of test stimuli used in the first experiment contained a total of 220 boom signatures. One hundred and eighty of these signatures consisted of factorial combinations of four boom-shaping parameters associated with the symmetrical front-shock-minimized signatures shown in figure 2. These parameters were

peak overpressure level ΔP_{\max} of a boom signature, front-shock rise time τ_1 , secondary rise time τ_2 , and ratio of front-shock overpressure to peak overpressure level $\Delta P_f/\Delta P_{\max}$, denoted as overpressure ratio. The factorial combinations consisted of five peak overpressure levels (1.0, 1.3, 1.6, 2.0, and 2.4 lbf/ft²), three front-shock rise times (1, 2, and 4 msec), three secondary rise times (20, 30, and 50 msec), and four overpressure ratios (0.25, 0.50, 0.75, and 1.00). (Note that the special case for $\Delta P_{\max}/\Delta P_f$ of 1 corresponds to a flattop signature with overpressure ΔP_{\max} .) The duration for all FSM signatures was 300 msec.

The remaining 40 stimuli used in the first experiment consisted of 8 additional boom shapes, each of which was presented at the 5 overpressure levels just given. Four of these shaped booms corresponded to boom signatures derived from candidate low-boom aircraft designs. These shapes, which are presented in figures 3(a) to 3(d), are not shown to scale. Note that each shape in figure 3 is asymmetrical and that maximum overpressure occurs during the initial compression phase of each signature. One signature (fig. 3(a)) is an asymmetrical N-wave, and two signatures (figs. 3(b) and 3(c)) are front-shock minimized with two pressure steps to peak overpressure. These three signatures had durations of 300 msec each. The fourth signature (fig. 3(d)) reaches peak overpressure in five pressure steps and has a duration of 253 msec.

The final four shaped booms (not shown) were obtained by modifying the four asymmetrical boom shapes to make them symmetrical. This modification was accomplished by making the rarefaction phase of each signature identical in shape and amplitude (but opposite in sign) to the compression phase. The duration of each “symmetrized” signature was the same as that of the corresponding asymmetrical signature. This set of 40 candidate booms is referred to as the CBOOM (candidate boom) stimuli set. This designation was given to distinguish these booms from those defined by the factorial combinations of FSM parameters.

The stimuli for the 220 boom signatures in the first experiment were organized into 5 sessions of 44 booms each, and the booms were randomly assigned to the sessions. To minimize order effects, the booms within each session were presented in both forward and reverse sequence. Thus, one-half of the subjects heard the booms in forward order and the remaining one-half heard them in reverse order. The presentation sequences of the sessions were counter-balanced by applying balanced Latin squares to further minimize order effects.

Test stimuli for second experiment. The second experiment used 4 signature shapes, each presented at 7 overpressure levels, for a total of 28 stimuli. Three of the signature shapes were selected from the set of front-shock-minimized signatures used in the first experiment. The three shapes differed only in front-shock rise time (1, 2, and 4 msec). The secondary rise time and the overpressure ratio for each signature were 30 msec and 0.50, respectively. The fourth signature shape was a symmetrical N-wave with a rise time of 3 msec and a duration of 300 msec. These 28 booms comprised 1 test session. The order of presentation of the booms within the session was randomized, and the presentation order was alternately presented in forward and reverse sequence to further reduce order effects.

Scaling Methods

The first experiment utilized the set of 220 boom stimuli described previously. For this experiment, subjective reactions were obtained using a continuous 11-point numerical category scale, which is described in appendix A. The scale was characterized at the low end (with a scale value of 0) by the words “NOT LOUD AT ALL” and at the high end (with a scale value of 10) by the words “EXTREMELY LOUD.” The instructions given to the subjects explaining how to use the scale are given in appendix A.

The second laboratory test used the method of constant stimuli to determine approximate acceptability thresholds for the four boom shapes described earlier. This method involved simply asking the subjects to indicate whether a boom would be acceptable or unacceptable to them if it were heard three or four times a day during their daily activities within or about their homes. The instructions for this experiment are given in appendix B.

Note that it was not the intent of this second experiment to establish absolute acceptability thresholds applicable to “real-world” situations. The problems inherent in projecting from the laboratory to the real world are well recognized. However, documenting acceptability within the laboratory simulator and comparing the resultant data with acceptability results obtained by others within more realistic situations were considered useful. The acceptability data were used to establish laboratory acceptability thresholds and to relate numerical category scale results to these thresholds.

Test procedure. Upon arriving at the laboratory, the subjects were briefed on the overall purpose of the two experiments, the test procedure to be followed, the system safety features, and their rights

as test subjects. The subjects then were taken individually to the simulator and given the instructions regarding the specific tasks required in the first experiment (appendix A).

Prior to entering the simulator, each subject was asked to listen to several boom signatures (which were played with the simulator door open) to become familiar with the type of sounds they would be required to evaluate in the experiment. At this point, the subject was given a practice scoring sheet and seated in the simulator with the door closed. A series of 10 practice booms was presented, and the subject was asked to rate each of these using the 11-point numerical category scales on the practice scoring sheets. Upon completing the practice scoring session, the scoring sheet was collected, and any questions regarding the scoring procedure were answered. Scoring sheets for the first test session then were distributed, and the first session was conducted. After the first session was concluded, the subject was returned to the waiting room and remained there until the other subjects in the group completed their first session of the day. This procedure, except for the familiarization and practice sessions, was repeated for the remaining four sessions of the first experiment.

Upon concluding the first experiment, the subjects were returned individually to the simulator to complete the single session of the second experiment. They were instructed on the use of the scaling method, underwent a short practice session, and then performed the actual test session. At this point, their participation in the experiments was completed.

Data analysis. Sonic boom signatures were measured without subjects in the simulator by using a special low-frequency response microphone that was located approximately at ear level for a seated subject. These measurements were computer processed to calculate sound exposure level in terms of three metrics and to calculate two loudness metrics. The metrics used in calculating sound exposure level were based on three frequency weightings: unweighted, A-weighted, and C-weighted. Sound exposure level is given, in the time domain, by the following expression:

$$L_{XE} = \log_{10} \left[\frac{1}{t_0} \int_{t_1}^{t_2} \frac{p_X^2(t) dt}{p_{\text{ref}}^2} \right]$$

where L_{XE} is the sound exposure level in decibels for frequency weighting X ($X = U, C$, and A for unweighted, C-weighted, and A-weighted, respectively); $p_X(t)$ is the instantaneous time varying X-weighted

sound pressure; p_{ref} is the reference sound pressure of 20 μPa ; t_0 is the reference time of 1 sec for sound exposure level; and t_1 and t_2 are the effective beginning and ending times, respectively, of a boom signature. This equation, although defining sound exposure level, was not actually used to calculate it in the present study. Instead, the sound exposure level was calculated in the frequency domain by using each of the three frequency weightings.

The loudness metrics used were the Stevens Mark VII Perceived Level (PL) and the Zwicker Loudness Level (LLZ). The calculation procedure for PL and LLZ was based on the frequency domain methods described in references 4 and 6. This procedure uses a summation of weighted one-third octave band levels and a reference time t_0 of 0.07 sec. The use of a reference time of 0.07 sec instead of the 1 sec used to calculate sound exposure levels increases the computed one-third octave band levels by a constant value of 11.5 dB. Once the one-third octave band levels were obtained, the weighting and summation procedures described in reference 7 were used to determine PL and LLZ .

Estimates of peak front (positive) and rear (negative) overpressures of the symmetrical FSM booms were obtained from the measured boom signatures. Because these estimates generally differed slightly from each other, the averages of the absolute values of the two were calculated and used to characterize peak overpressures of the symmetrical signatures.

Various statistical analyses were conducted using the obtained subjective ratings. These analyses included calculation of basic statistical parameters, correlation analysis, and regression analysis. Details of the analysis methods can be found in reference 8 or in most standard statistical texts.

Discussion of Results

FSM Boom Parameter Effects

Front-shock rise time and overpressure ratio. The overall effects of the front-shock rise time and the overpressure ratio on the FSM stimuli set are presented in figures 4(a) and 4(b), respectively. The loudness ratings of figure 4(a) have been averaged over the overpressure ratio and peak overpressure factors, and those of figure 4(b) were averaged over front-shock rise time and peak overpressure. Both figures present results for each of the three secondary rise times. These figures show that boom loudness decreased with increasing front-shock rise time (fig. 4(a)) and increased with increasing overpressure ratio (fig. 4(b)). These trends are consistent with

the results of prior experimental and analytical studies (e.g., refs. 3 and 4) and illustrate the potential loudness reductions attainable through manipulating these two shaping parameters.

Secondary rise time. The data in figures 4(a) and 4(b) show that subjective loudness ratings did not depend upon the length of the secondary rise time. Consequently, the loudness ratings were averaged over secondary rise time, and the results presented in the remainder of this paper will be based upon these averaged data. However, secondary rise time would be expected to influence loudness if its magnitude approached that of the initial rise time (e.g., see ref. 4).

Overpressure ratio. The effects of overpressure ratio upon subjective loudness for several specific boom shapes within the FSM stimuli set are shown in figures 5(a) to 5(c). Results are presented for FSM shapes defined by each front-shock rise time and the maximum (approximately 2.3 lbf/ft²) and minimum (approximately 1.0 lbf/ft²) peak overpressures for each. Data for the remaining peak overpressure values (not shown) fall between the two curves shown in each figure. Thus, these curves represent the envelope of subjective loudness responses obtained for the FSM stimuli set and provide a more detailed view of the overall effects that were displayed in figure 4. The curves show that the effects of overpressure ratio were consistent for each front-shock rise time and peak overpressure level.

The loudness predictions of reference 4 indicated that when $\Delta P_f = \Delta P_{\max}$ (see fig. 2) the loudness level is independent of the secondary rise time and equal to the loudness of an N-wave having the same peak overpressure and rise time. This special case corresponds to the FSM boom signatures in the present study that have an overpressure ratio of unity. These signatures are called flattop signatures. To verify the predictions of reference 4, the mean loudness ratings of the flattop signatures that had a peak overpressure of 1 lbf/ft² were compared with N-wave loudness ratings obtained in a recent laboratory test conducted by the authors (data not yet published). These recent test data were obtained from a group of 32 test subjects who rated the loudness of several N-wave signatures using a numerical category scale identical to that of the present study. The N-wave loudness ratings obtained in that test for a peak overpressure of 1 lbf/ft² and for rise times of 1, 2, and 4 msec are represented by the dashed lines in figures 5(a) to 5(c), respectively. As shown in the figures, the subjective loudnesses of the flattop and the N-wave signatures (for ΔP_{\max} of 1 lbf/ft²) agreed

very well. This agreement verifies that flattop signatures and N-waves of equal rise time and peak overpressure would be perceived as equally loud. Thus, designing for a flattop signature that had the same peak overpressure and rise time as an N-wave would not introduce an additional loudness penalty nor would it provide a loudness advantage.

Boom-Shaping Considerations

The previous section verified the predicted equivalence between FSM booms and N-waves for the special case of flattop booms and indicated that significant reductions in subjective loudness could be achieved by modifying the front-shock parameters of the nonflattop booms. A more detailed look at boom-shaping effects is presented in figures 6(a) to 6(c). These figures show the mean subjective loudness ratings for each factorial combination of peak overpressure level, overpressure ratio, and front-shock rise time. (The data were averaged over the secondary rise time.) Each plot in figure 6 contains the results for a single front-shock rise time. Also shown in each plot (by the inverted triangles) are the mean subjective loudness ratings for N-wave signatures having the same rise time as the corresponding FSM signatures. The N-wave data were obtained in the unpublished study mentioned previously.

The results in figure 6 show that all FSM signatures, for comparable peak overpressures, were rated quieter than those of the corresponding N-waves. For a given loudness rating, the FSM signatures, except for the flattop signatures, had significantly higher peak overpressures than those of the N-wave signatures. These data also show that various degrees of loudness reduction (relative to N-wave loudness) were achievable, depending upon the particular combination of boom shaping parameters selected.

Specific examples of loudness reduction tradeoffs attainable by front-shock minimization are illustrated in figures 7(a) and 7(b) for boom signatures having peak overpressures of 1 lbf/ft² and 2 lbf/ft². These figures show that the quietest booms were those with the largest front-shock rise times and lowest front-shock overpressures. For example, consider the flattop signature (with an overpressure ratio of 1) which has a front-shock rise time of 1 msec and a maximum overpressure of 1 lbf/ft² (fig. 7(a)). The mean loudness rating for this signature was 5.7. Now consider two options for reducing boom loudness: (1) maintaining an overpressure ratio of unity and increasing front-shock rise time to 4 msec and (2) maintaining a front-shock rise time constant (at 1 msec) and reducing the overpressure ratio to 0.25. In the first case, the loudness ratings decreased from 5.7

to 3.5, which is a decrement of 2.2 scale units. In the second case, the loudness rating decreased to 1.6, which is a decrement of 4.1 scale units. Thus, for the range of front-shock rise times in this study, the reduction of front-shock overpressure provided the largest decreases in subjective loudness. If both options were selected, the loudness rating would decrease to 0.45, which is a reduction of 5.25 scale units. This decrease would correspond to a high level of acceptability. (See the section entitled “Boom Acceptability Considerations.”)

Metric Considerations

Correlation Results

Mean loudness ratings were calculated for each boom signature in the first experiment. Plots showing these ratings as a function of level for the metrics ΔP_{\max} , L_{CE} , L_{AE} , and PL are presented in figures 8(a) to 8(d). The L_{UE} and LLZ metrics are not shown because they are very similar to the ΔP_{\max} and PL metrics, respectively. A cursory inspection of these figures shows very large scatter associated with peak overpressure (or equivalently with L_{UE}), thus implying that it is a poor metric for quantifying subjective loudness to sonic booms. Significant reduction in scatter was evident for L_{CE} , and the least scatter occurred for L_{AE} , PL , and LLZ . These findings indicate that L_{AE} , PL , and LLZ have been effective in accounting for the effects of the FSM boom parameters as well as the shape differences associated with the CBOOM stimuli set.

Linear correlation coefficients between metric levels and mean loudness ratings have been calculated for each metric and are summarized in table I. The correlation coefficients provide a measure of the relationships between metric levels and loudness ratings as well as a basis for comparing between metrics. The correlation coefficients are presented in table I for the total stimuli set (220 booms) as well as several subgroups of the stimuli set. The subgroupings were the subset comprised of the front-shock-minimized booms (180 booms) only, the CBOOM subset (40 booms), the symmetrical booms within the CBOOM subset (20 booms), and the asymmetrical booms within the CBOOM subset (20 booms). Values of the correlation coefficients ranged from 0.359 to 0.977, and all were statistically different from zero ($P < 0.01$). The lowest correlations were observed for ΔP_{\max} , L_{UE} , and L_{CE} . The highest correlations occurred for L_{AE} , PL , and LLZ .

The high degree of relationship observed between the LLZ , PL , and L_{AE} metrics and the loudness ratings does not necessarily imply that these metrics

are equally precise as loudness predictors. Determination of the best predictor metrics requires evaluation of the relative accuracies of the metrics, i.e., prediction errors, and is discussed in the following section.

Metric Prediction Accuracy

The method used to assess metric prediction accuracy involved application of residual analysis to the data for each metric. Specifically, polynomial regression analysis was used to determine the best-fit curve describing the relationship between mean loudness ratings and level of each metric of figure 8. The appropriate order of the polynomial fit for each metric was determined by statistical analysis of the additional variance explained by including higher order terms (such as quadratic or cubic terms) in the regression model. The polynomial regression equation for each metric then was used to obtain estimated or predicted loudness ratings based on the measured levels of each test sound. The difference between each predicted and measured loudness rating is defined as the residual or, equivalently, the prediction error. The standard deviation of the prediction errors for each metric is the standard error of estimate about the regression curve for that metric and is an indicator of how accurately the metric predicts annoyance. The smaller the standard error of estimate, the greater the prediction accuracy. The resulting standard errors of estimate for each metric are displayed in figure 9. These data show that the least-accurate predictors were L_{UE} and L_{CE} , which had standard errors of estimate of approximately 1.66 and 0.97 scale units. The most accurate predictor was L_{AE} (with a standard error of estimate equal to 0.35 scale units), followed closely by LLZ and PL (with a standard error of estimate equal to 0.46 and 0.47 scale units, respectively). Thus, the L_{AE} metric displayed a slight advantage over the PL and LLZ metrics in terms of loudness prediction accuracy. However, the differences between the prediction accuracies of the L_{AE} , PL , and LLZ metrics were not statistically significant. Consequently, any one of these metrics could be used as loudness predictors without compromising prediction accuracy.

CBOOM Stimuli Set Results

The asymmetrical booms within the CBOOM stimuli set were included in this study to investigate whether the subjective loudness and acceptability characteristics of these signatures offered any loudness advantages compared with the symmetrical FSM signatures. This investigation was accomplished by comparing, for equal L_{AE} , the obtained

loudness ratings of the symmetrical FSM and asymmetrical signatures. The comparison was made by fitting the rating versus the L_{AE} data of each data set with second-order polynomial regression curves. The resulting comparison is presented in figure 10. The solid curve in the figure represents the symmetrical FSM signatures, and the dashed curve corresponds to the asymmetrical signatures. These results show that, for the middle range of the L_{AE} values, the asymmetrical signatures were rated less loud than those of the symmetrical FSM signatures. This difference was statistically significant ($P < 0.01$) and implies that sonic boom signature asymmetry introduced loudness reductions that are not predicted by loudness metrics such as PL and L_{AE} . However, the number of asymmetric signatures and the degree of asymmetry of the boom signatures in this study were very limited. Thus, definitive conclusions regarding loudness effects of boom asymmetry cannot be made based upon the present results.

Boom Acceptability Considerations

The previous discussion of boom shaping (in the section entitled “Boom-Shaping Considerations”) defined the subjective loudness effects of the individual FSM shaping parameters by using numerical category scale ratings. This scale provided data in a format appropriate for use in statistical analysis and loudness estimation, but it gave no information concerning the acceptability of the various booms. Although substantial differences in loudness responses were observed as boom parameters varied, it was not known whether all, none, or some of the booms were unacceptable in an absolute sense. Consequently, the second experiment was conducted to obtain data for use in quantifying boom unacceptability within the laboratory environment. The data were used to approximately relate the numerical category scale data of the first experiment to a meaningful laboratory scale of acceptability and to compare this scale with the acceptance results obtained by other investigators.

The subjective parameter of interest in the acceptability test was the percent of subjects that rated a given boom-level combination as unacceptable. This parameter is shown in figure 11 as a function of the L_{AE} metric level for the four boom signatures of the second experiment. This L_{AE} metric was selected because it was shown earlier to be a slightly better predictor of loudness than PL and LLZ . The curve in the figure is the best-fit second-order least-squares polynomial for these data. This polynomial then was used to estimate the percentage of unacceptable values for the selected L_{AE} levels. Similarly,

the numerical category scale loudness rating data for each L_{AE} (shown in fig. 8(c)) were fitted with a polynomial, and estimates of mean loudness ratings were obtained for the same L_{AE} levels. The two sets of estimates then were used to define the relationship between acceptability and the numerical category scale results of the present study. This relationship is displayed in figure 12. This figure can be used to aid in interpreting the numerical category scale loudness ratings in terms of boom unacceptability. For example, numerical category scale values of 4.54 and 2.64 correspond to ratings that are 50 and 80 percent unacceptable, respectively. Thus, booms whose mean numerical category scale loudness ratings exceeded 4.54 would have been rated unacceptable by a majority of the test subjects. Numerical category scale ratings exceeding approximately 7 would have been rated unacceptable by all subjects.

Because the loudness acceptability results just described were developed within the laboratory environment, it was of interest to determine how these results compared with the acceptability criteria obtained or proposed by others. Ascertaining whether the laboratory environment introduced significant biases that would seriously limit the validity and applicability of these results was particularly important. To address this issue, the values of each noise metric corresponding to numerical category scale ratings of 2.64 (20 percent unacceptable) and 4.54 (50 percent unacceptable) were estimated from polynomial regressions of loudness ratings and metric values. The results of applying this procedure are given in table II, which contains the estimated metric levels for 20 and 50 percent boom loudness unacceptability.

The next step was to compare the calculated metric values with the metric level criteria that have been considered by others. Unfortunately, the available data are limited. One study (ref. 9) which obtained subjective responses to simulated outdoor sonic booms (N-waves) determined that 20 percent of test subjects who heard these booms at a PL level of 90 dB rated them as unacceptable. This finding compares very well with the results in table II which indicate that 20 percent of the subjects in the present test found a PL level of 90.4 dB to be unacceptable. Note, however, that the method used to determine PL in reference 9 was based on a simplified predictive procedure and not upon the Stevens Mark VII method. Another psychoacoustic study (ref. 10) developed noise simulation systems that were placed into the homes of 12 families; annoyance, interference, and acceptance response ratings were obtained daily and weekly from these subjects. As part of the study, the subjects were asked, on a weekly

basis, to indicate whether or not the sounds that they were exposed to in the previous week would be acceptable if they were to continue indefinitely. Using results presented in tables 5 to 7 of reference 10, the present authors determined that an L_{AE} level of approximately 79 dB (which was heard 30 times per day) corresponded to 50 percent “YES” responses to this question. This level is indicated by the vertical dashed line on the right of figure 11. From table II, we see that 50 percent of the subjects in the present study indicated that an L_{AE} level of 80 dB would be acceptable if heard three or four times a day.

Recent studies (refs. 11 and 12) to assess loudness and other environmental impacts of an HSCT selected as tentative sonic boom loudness acceptability goals a PL of 90 dB (ref. 11) and the A-weighted sound exposure levels of 72 dB for corridors and 65 dB for unconstrained flight (ref. 12). (Note that the selected criteria levels in both refs. 11 and 12 were based upon surveys and analyses of human response data available at the time of the respective publications.) The two A-weighted sound exposure levels of reference 12 are indicated by the two leftmost vertical dashed lines in figure 11. In terms of the data of the present study, an L_{AE} boom level of 72 dB was acceptable to approximately 88 percent of the test subjects. This level corresponds to a high degree of acceptability and can represent a reasonable criterion for corridors. In this sense, the current laboratory results compare reasonably well with the recommendation of reference 12. The agreement between the laboratory criteria and the results and recommendations of these other studies implies that the validity of the laboratory absolute acceptability results may apply to “real-world” environments. This observation, however, remains to be confirmed by additional in-home testing that is scheduled to be conducted by Langley Research Center.

Conclusions

The sonic boom simulator of the Langley Research Center was used to quantify human subjective loudness response to a wide range of shaped sonic boom signatures. In addition, laboratory acceptability judgments were obtained for a small subset of the signatures. The loudness and acceptability results validated the potential of boom shaping to significantly improve public acceptance of sonic booms. Front-shock minimization was shown to be an effective method for reducing boom loudness; that is, significant loudness reductions were achieved by modifying front-shock parameters (such as rise time and overpressure ratio) without the necessity of reducing peak overpressure of the signatures. Subjective loud-

ness responses to various combinations of front-shock parameters were quantified in detail and related to a laboratory-derived threshold of unacceptability. Using the laboratory acceptability scale, the results of this study were compared, where possible, with acceptability criteria proposed in the literature. The specific conclusions and comments pertinent to the results of this study are summarized as follows:

1. The effects of varying the front-shock minimization (FSM) shaping parameters were consistent with results reported by other investigators. Generally, increasing front-shock rise time and/or decreasing front-shock overpressure were very effective in reducing subjective loudness.
2. Secondary rise time did not affect subjective loudness ratings for the range of values (20 to 50 msec) used in this study. This result, however, will not apply if secondary rise time is made sufficiently small or is comparable to the rise time of the front shock.
3. The flattop signatures (with an overpressure ratio of 1.0) were observed to be approximately equal in loudness to those of N-waves having the same rise time and peak overpressure. Thus, no loudness penalty would be introduced, nor loudness advantage gained, by designing for a flattop signature instead of an N-wave.
4. Correlation and prediction error analyses of the noise metrics indicated that L_{AE} , PL , and LLZ performed well and effectively accounted for the effects of boom shaping. Based upon the results of this study, it is reasonable to conclude that any one of the three metrics could be used to estimate boom loudness effects.
5. The asymmetrical boom signatures contained within the CBOOM stimuli set were rated slightly quieter than those of the front-shock-minimized signatures, for equivalent L_{AE} , over the midrange values of L_{AE} . However, the number of asymmetrical booms (and the degree of asymmetry) included in this study was limited. Definitive conclusions regarding asymmetry must await the results of additional boom asymmetry studies.
6. Comparison of laboratory acceptability results with acceptability data obtained by others in more realistic situations indicated good agreement. This agreement implies that the validity of absolute acceptability results based upon laboratory tests may extend to more realistic

situations. This result, however, must also be confirmed by further laboratory and in-home testing.

7. The results presented in this paper were obtained for simulated outdoor sonic boom signatures. Additional studies will be conducted to quantify subjective loudness response to

simulated indoor signatures (defined as signatures modified to account for the effect of transmission through walls).

NASA Langley Research Center
Hampton, VA 23681-0001
August 28, 1992

Appendix A

Instructions for First Experiment: Instruction Set Number 1

The experiment in which you are participating will help us to understand the way people respond to various sounds produced by aircraft. We would like you to judge how LOUD some of these aircraft sounds are.

The experiment consists of five 4-min sessions. During each session, 44 aircraft sounds will be presented for you to judge. Before each session, you will be given 4 rating sheets, each containing 11 rating scales similar to the one shown below.

After each sound, there will be a few seconds of silence. During this interval, please indicate how loud you judge the sound to be by placing a checkmark along the scale. If you judge a sound to be only slightly loud, then place your checkmark close to the NOT LOUD AT ALL end of the scale, that is, near or

between a low number near the left end of the scale. Similarly, if you judge a sound to be very loud, then place your checkmark closer to the EXTREMELY LOUD end of the scale, that is, near or between a high number near the right end of the scale. A moderately loud judgment should be marked in the middle portion of the scale. In any case, please make only one checkmark on each scale. There are no right or wrong answers; we are only interested in your opinion of each sound.

Before entering the test facility, six sounds will be presented to acquaint you with the sounds you will hear in the experiment. After entering the test facility, you will be given a practice rating sheet and 10 more sounds will be presented to familiarize you with the process of making and recording your judgments. After the practice session, I will answer any questions you may have.

Thank you for your participation and help in conducting this experiment.

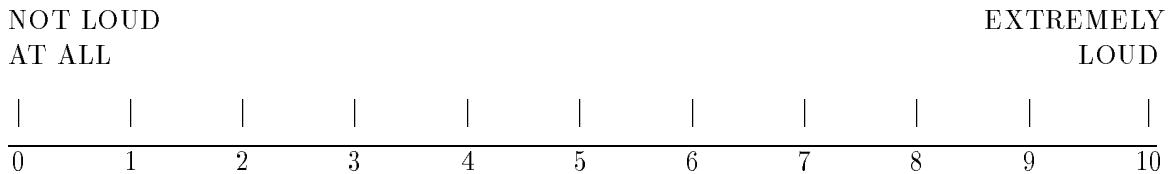

Appendix B

Instructions for Second Experiment: Instruction Set Number 2

We are now going to conduct a brief test in which we will ask your opinions concerning the acceptability of several sounds that you heard earlier. Twenty-eight sounds will be presented to you one at a time. Your task will be to indicate, after listening to each sound, whether or not you would find a sound acceptable if you were to hear it three to four times a day as you pursue your daily activities. Daily activities could include any or all of the following: working/relaxing in your yard, watching TV, eating, reading, conversation with friends/neighbors, or performing household chores. In making your judg-

ments, assume that none of the sounds would occur at night.

After listening to each sound please indicate, based upon the guidelines given above, your opinion as to whether the sound would be acceptable or unacceptable to you. You should make your evaluation by placing a checkmark in either the column labeled “NO” or the column labeled “YES” as shown in the example below.

		Acceptable	
		NO	YES
1.	_____		_____ <input checked="" type="checkbox"/>
2.	_____ <input checked="" type="checkbox"/>		_____

References

1. Niedzwiecki, A.; and Ribner, H. S.: Subjective Loudness of N-Wave Sonic Booms. *J. Acoust. Soc. America*, vol. 64, no. 6, Dec. 1978, pp. 1617–1621.
2. Leatherwood, Jack D.; Shepherd, Kevin P.; and Sullivan, Brenda M.: *A New Simulator for Assessing Subjective Effects of Sonic Booms*. NASA TM-104150, 1991.
3. Niedzwiecki, A.; and Ribner, H. S.: Subjective Loudness of “Minimized” Sonic Boom Waveforms. *J. Acoust. Soc. America*, vol. 64, no. 6, Dec. 1978, pp. 1622–1626.
4. Shepherd, Kevin P.; and Sullivan, Brenda M.: *A Loudness Calculation Procedure Applied to Shaped Sonic Booms*. NASA TP-3134, 1991.
5. Brown, Donald E.; and Sullivan, Brenda M.: Adaptive Equalization of the Acoustic Response in the NASA Langley Sonic Boom Chamber. *Proceedings of the Conference on Recent Advances in Active Control of Sound and Vibration*, C. A. Rogers and C. R. Fuller, eds., Technomic Publ. Co., Inc., 1991, pp. 360–371.
6. Johnson, D. R.; and Robinson, D. W.: Procedure for Calculating the Loudness of Sonic Bangs. *Acustica*, vol. 21, no. 6, 1969, pp. 307–318.
7. Pearsons, Karl S.; and Bennett, Ricarda L.: *Handbook of Noise Ratings*. NASA CR-2376, 1974.
8. Neter, John; and Wasserman, William: *Applied Linear Statistical Models*. Richard D. Irwin, Inc., 1974.
9. Higgins, Thomas H.; and Sanlorenzo, Ernest A.: *Psychophysical Tests of Potential Design/Certification Criteria for Advanced Supersonic Aircraft*. Rep. No. FAA-RD-75-10, U.S. Dep. of Transportation, Feb. 1975. (Available from DTIC as AD A009 296.)
10. Mabry, J. E.; and Oncley, P. B.: *Establishing Certification/Design Criteria for Advanced Supersonic Aircraft Utilizing Acceptance, Interference, and Annoyance Response to Simulated Sonic Booms by Persons in Their Homes*. Rep. No. FAA-RD-75-44, U.S. Dep. of Transportation, Mar. 1975. (Available from DTIC as AD A009 656.)
11. HSCT Concept Development Group, Advanced Commercial Programs: *1989 High-Speed Civil Transport Studies*. NASA CR-4375, 1991.
12. Brown, Jessica G.; and Haglund, George T.: Sonic Boom Loudness Study and Airplane Configuration Development. AIAA-88-4467, Sept. 1988.

Table I. Correlation Coefficients Between Mean Ratings and Each Metric for Various Stimuli Set Groupings

Grouping	ΔP_{\max} , lbf/ft ²	L_{UE} , dB	L_{CE} , dB	L_{AE} , dB	PL , dB	LLZ , dB
All booms	0.4937	0.5321	0.8587	0.9581	0.9561	0.9581
FSM booms	0.4835	0.5461	0.8430	0.9660	0.9580	0.9584
All CBOOM's	0.5036	0.4080	0.9399	0.9344	0.9558	0.9617
CBOOM's symmetrical	0.5863	0.5094	0.9168	0.9615	0.9514	0.9576
CBOOM's asymmetrical	0.4687	0.3590	0.9600	0.9636	0.9755	0.9770

Table II. Metric Levels Corresponding to Loudness Unacceptability Levels of 50 and 20 Percent

Metric	Percent unacceptable	
	50	20
L_{UE}	122.9	121.7
L_{CE}	103.0	99.5
L_{AE}	80.0	74.1
PL	96.0	90.4
LLZ	106.5	102.0

Figure 1. Sonic boom simulator.

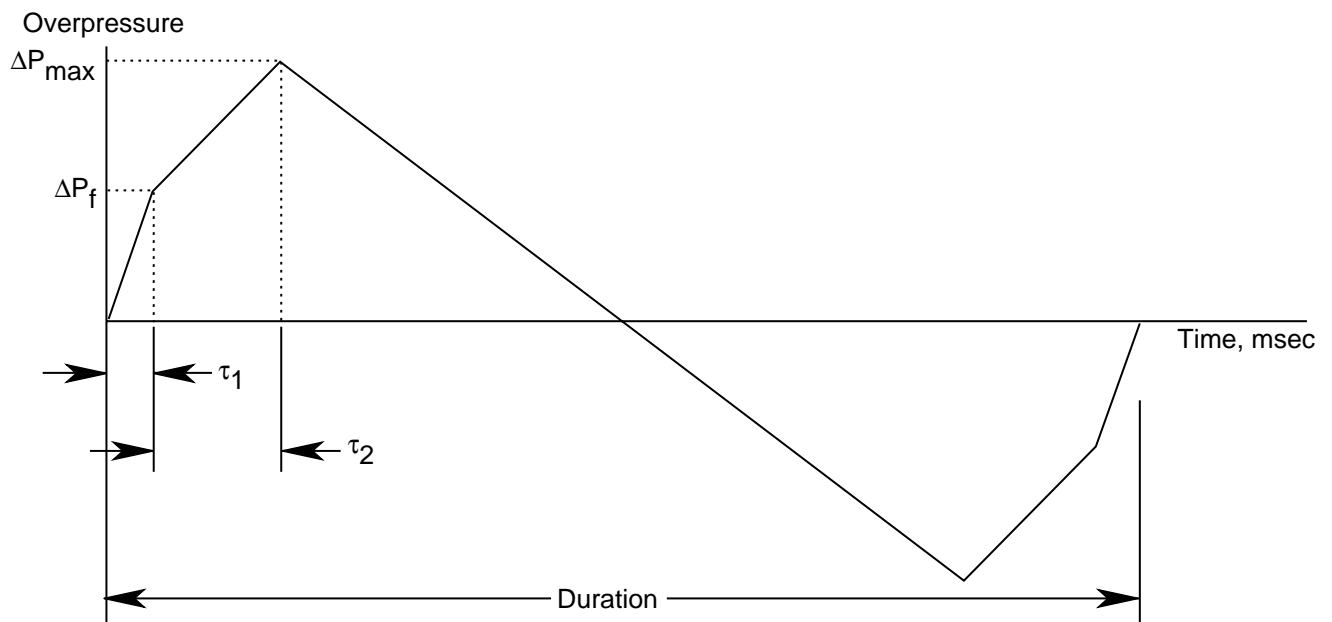
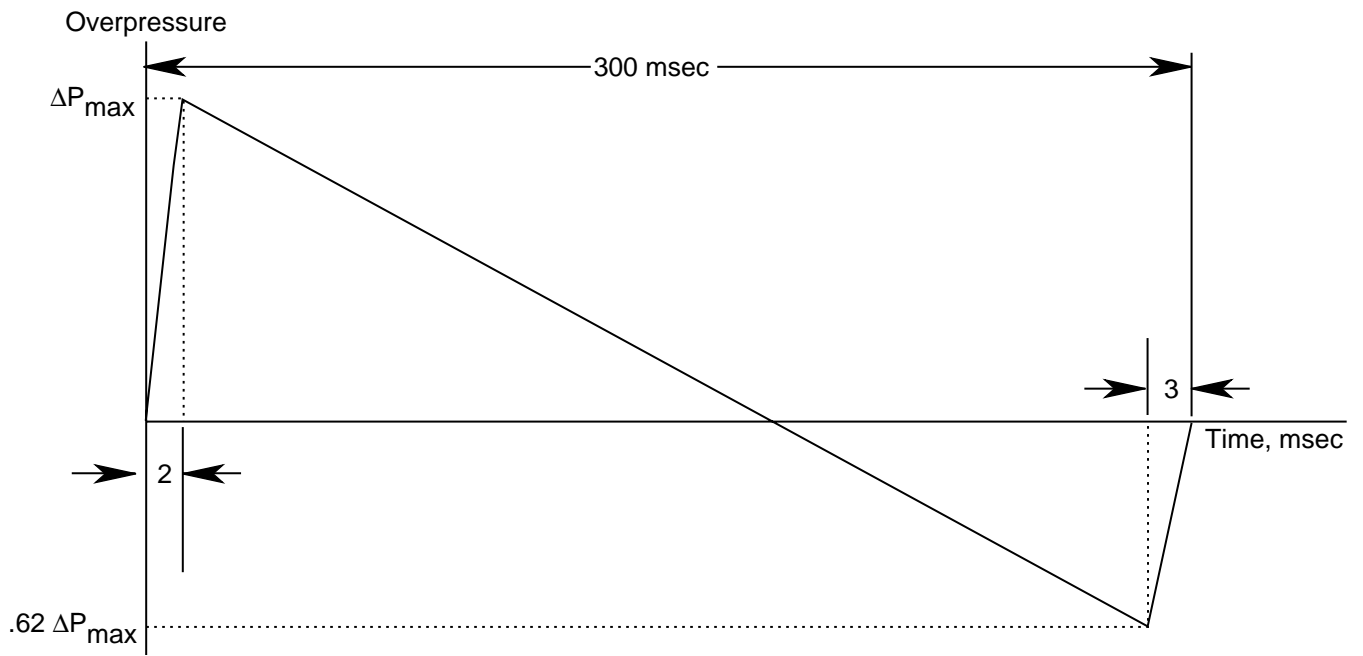
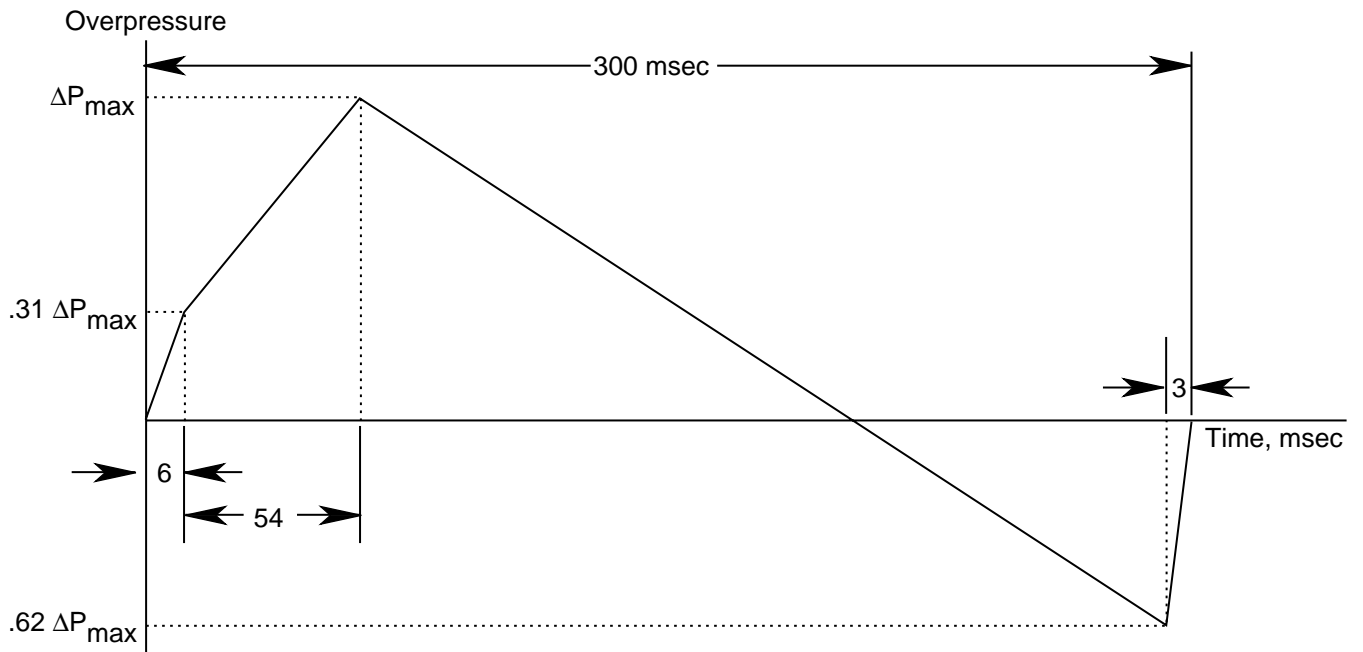

Figure 2. Shape parameters for front-shock-minimized sonic boom signatures.



(a) Candidate boom 1.



(b) Candidate boom 2.

Figure 3. Asymmetrical boom signatures included in study.

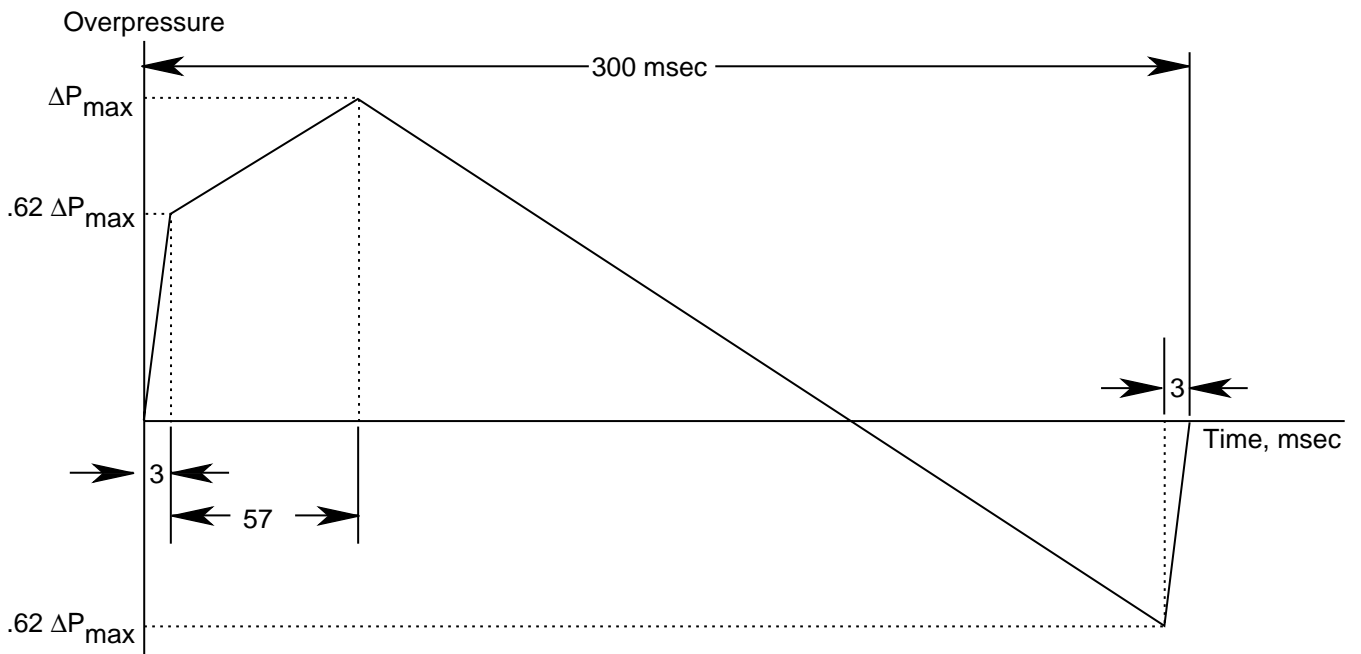

(c) Candidate boom 3.

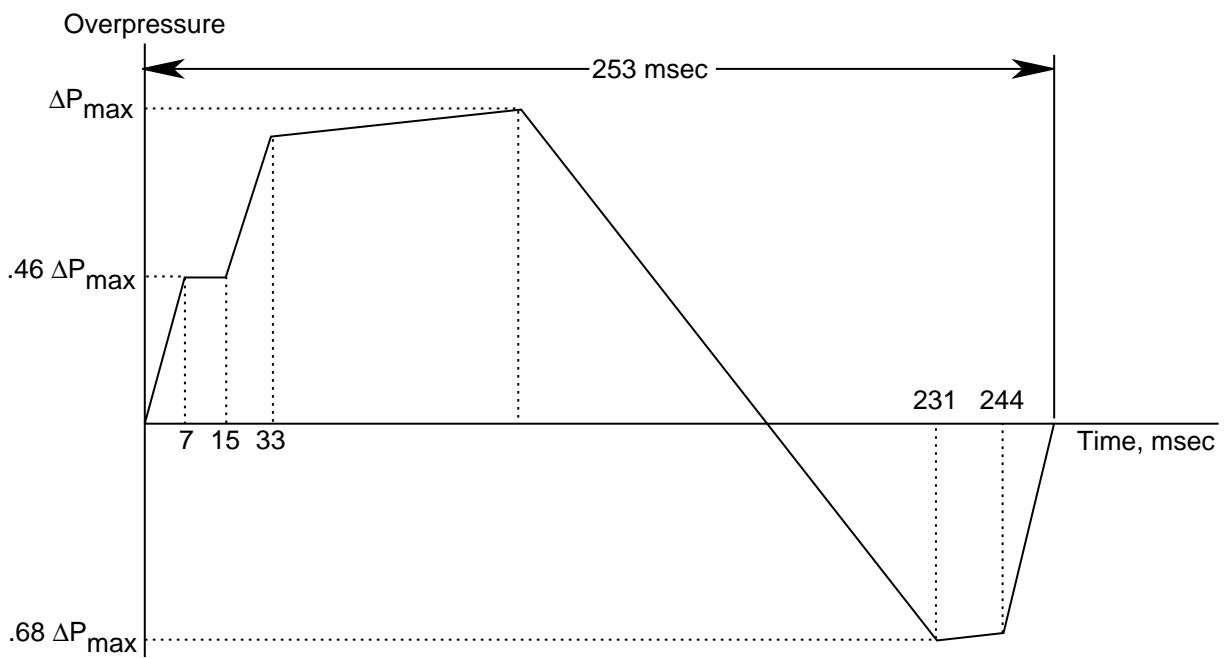

(d) Candidate boom 4.

Figure 3. Concluded.

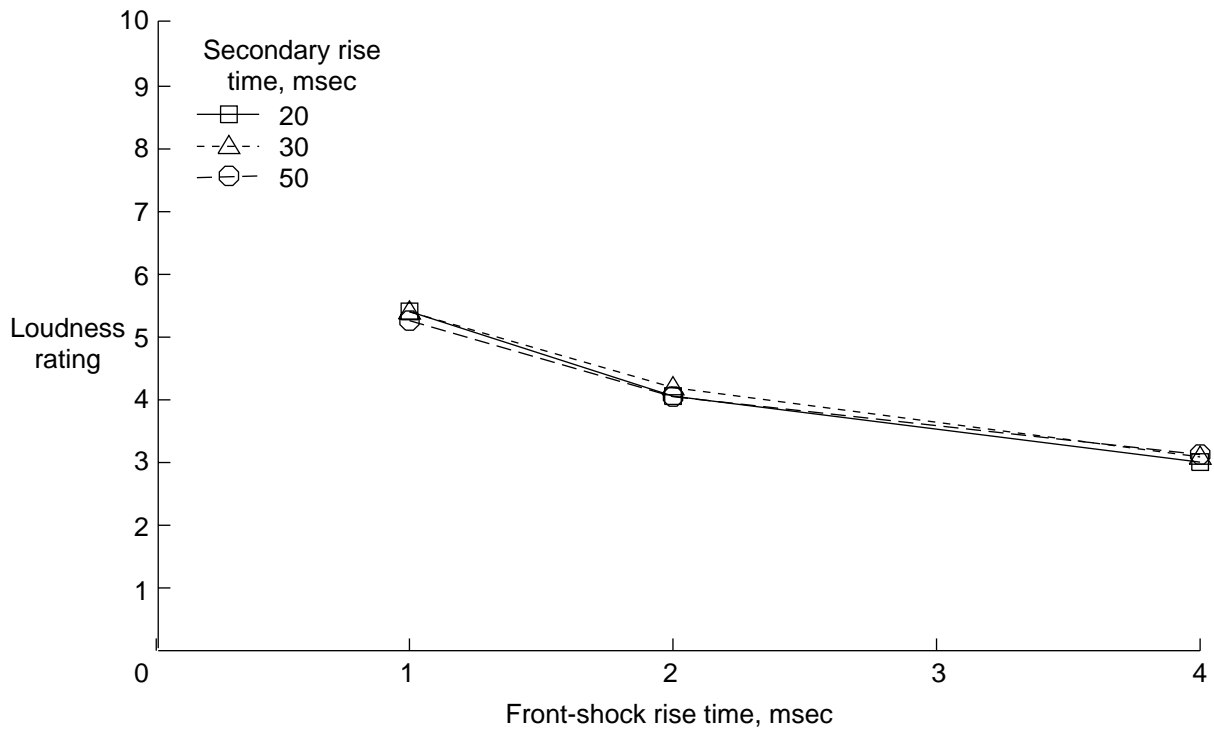

(a) Effect of front-shock rise time.

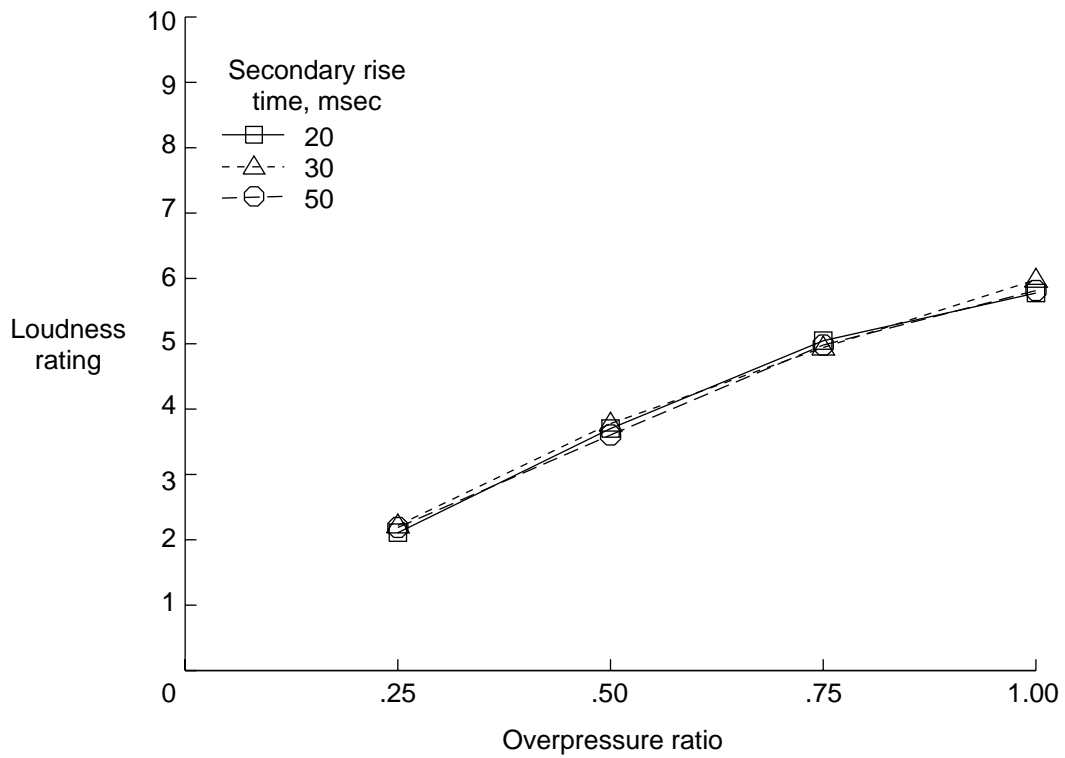

(b) Effect of overpressure ratio.

Figure 4. Overall effects on subjective loudness of front-shock rise time and overpressure ratio for each secondary rise time.

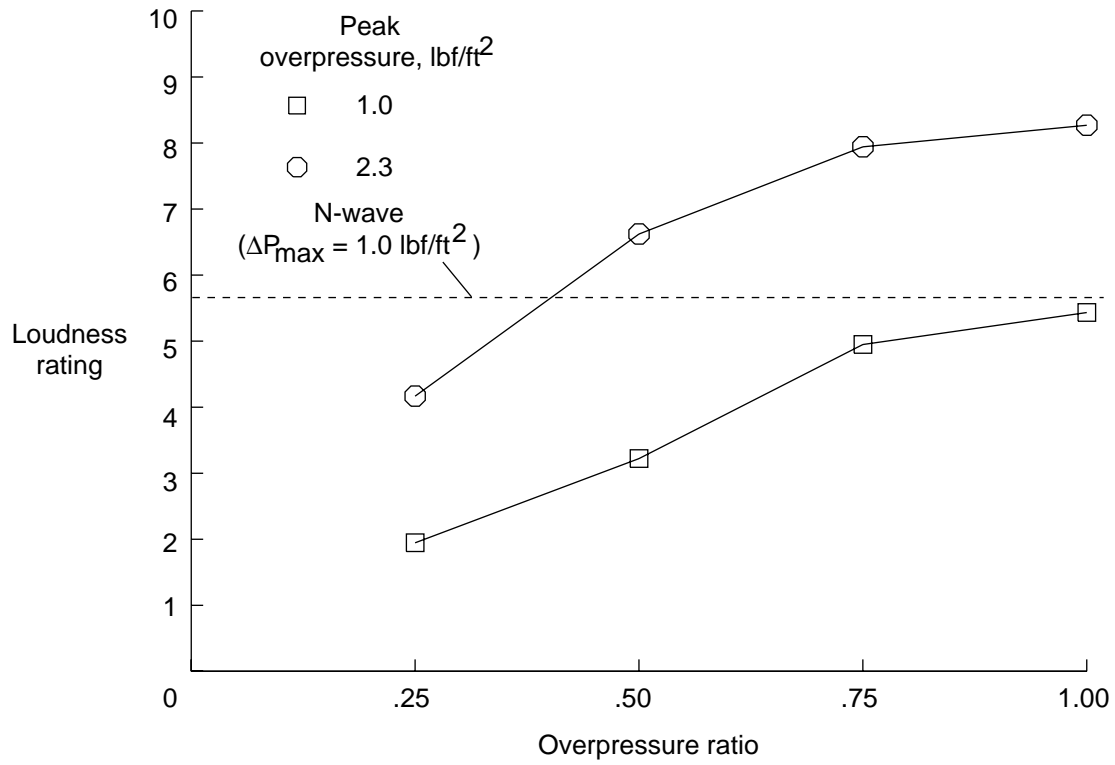

(a) $\tau_1 = 1 \text{ msec.}$

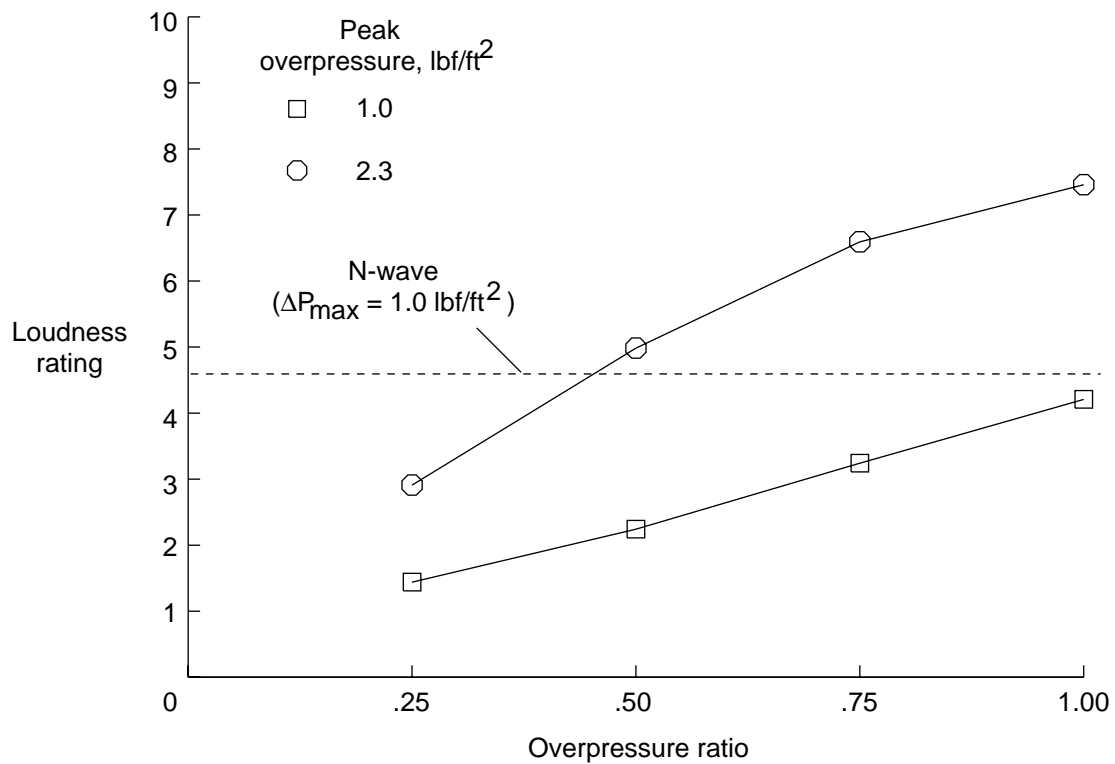

(b) $\tau_1 = 2 \text{ msec.}$

Figure 5. Subjective loudness as function of overpressure ratio for each front-shock rise time and for peak overpressures of 1.0 and 2.3 lbf/ft².

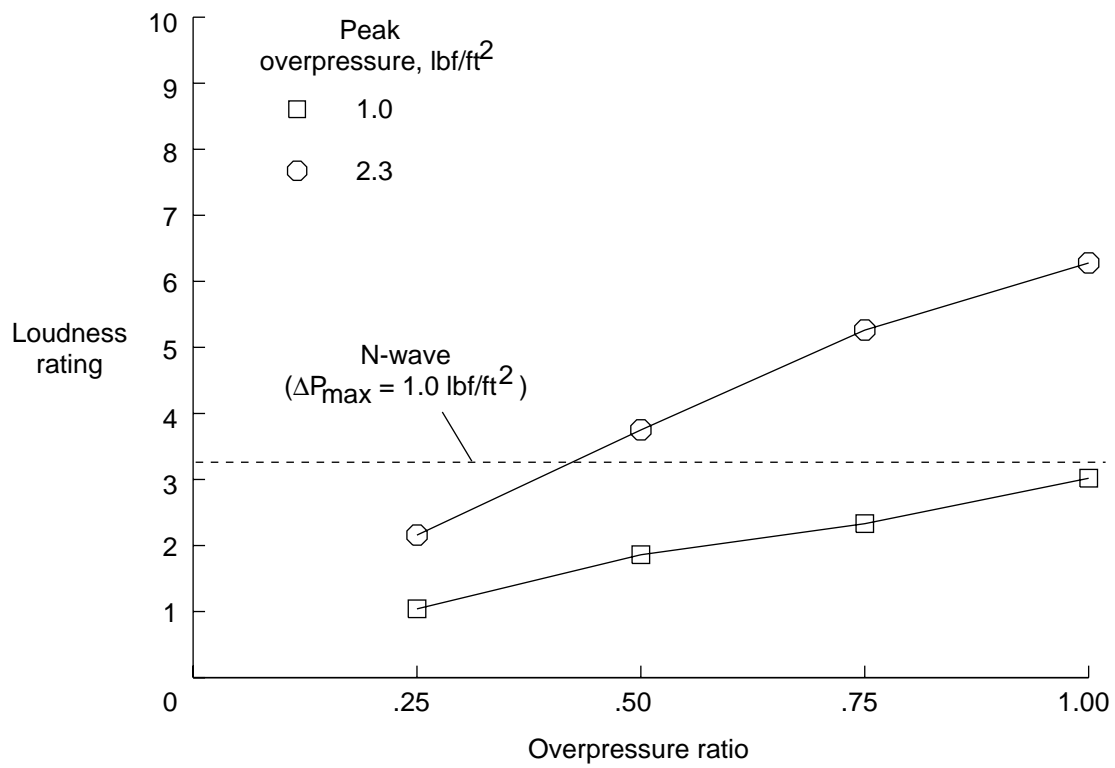

(c) $\tau_1 = 4 \text{ msec.}$

Figure 5. Concluded.

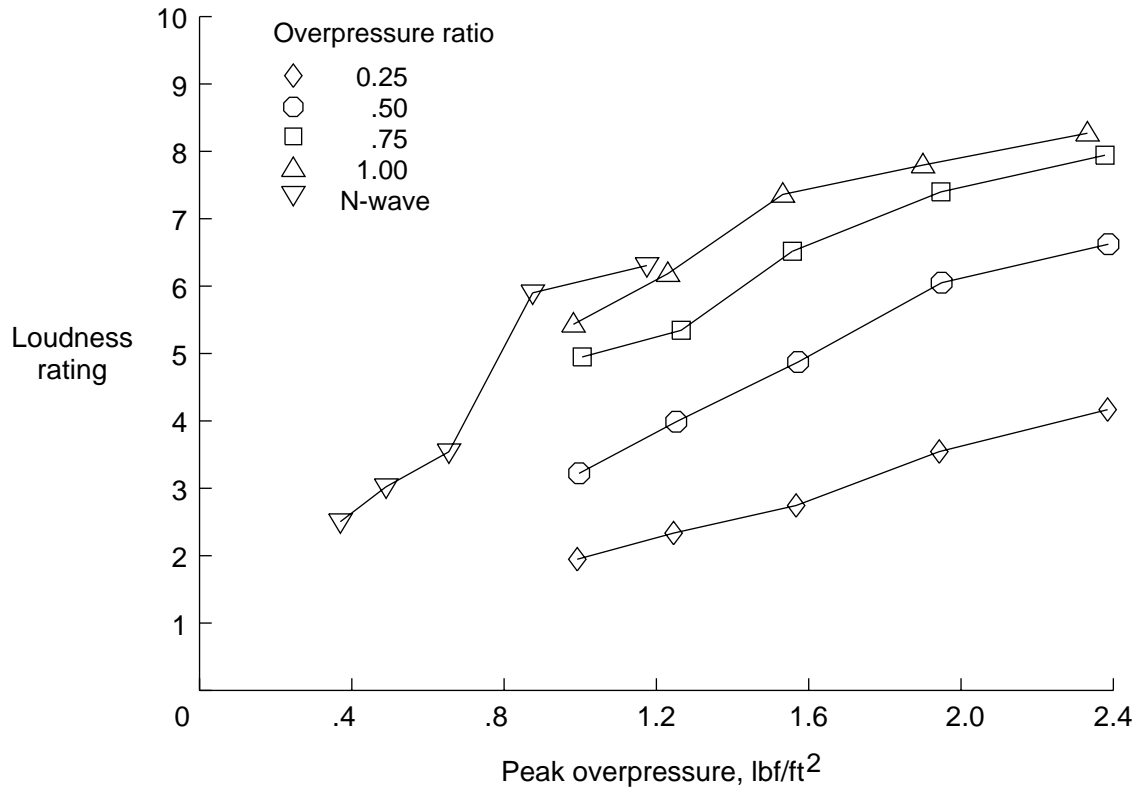

(a) $\tau_1 = 1$ msec.

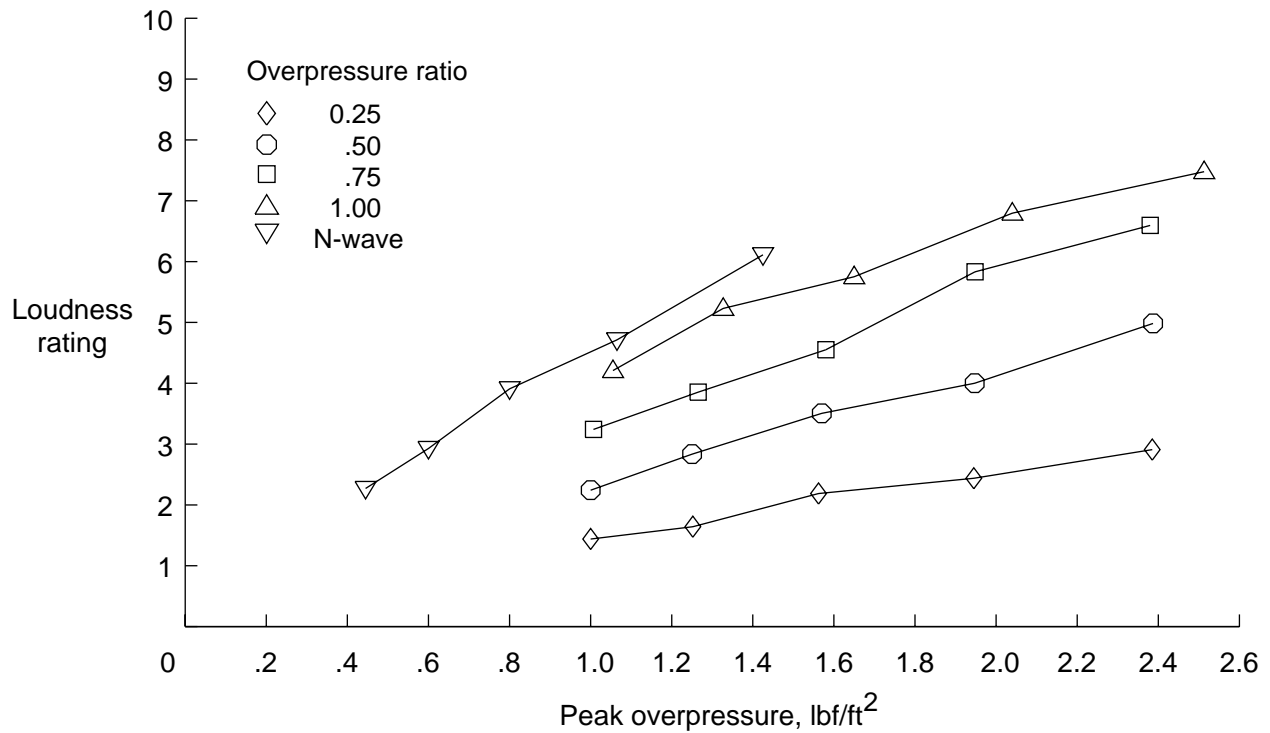

(b) $\tau_1 = 2$ msec.

Figure 6. Effect of peak overpressure level, overpressure ratio, and front-shock rise time on subjective loudness for front-shock-minimized signatures.

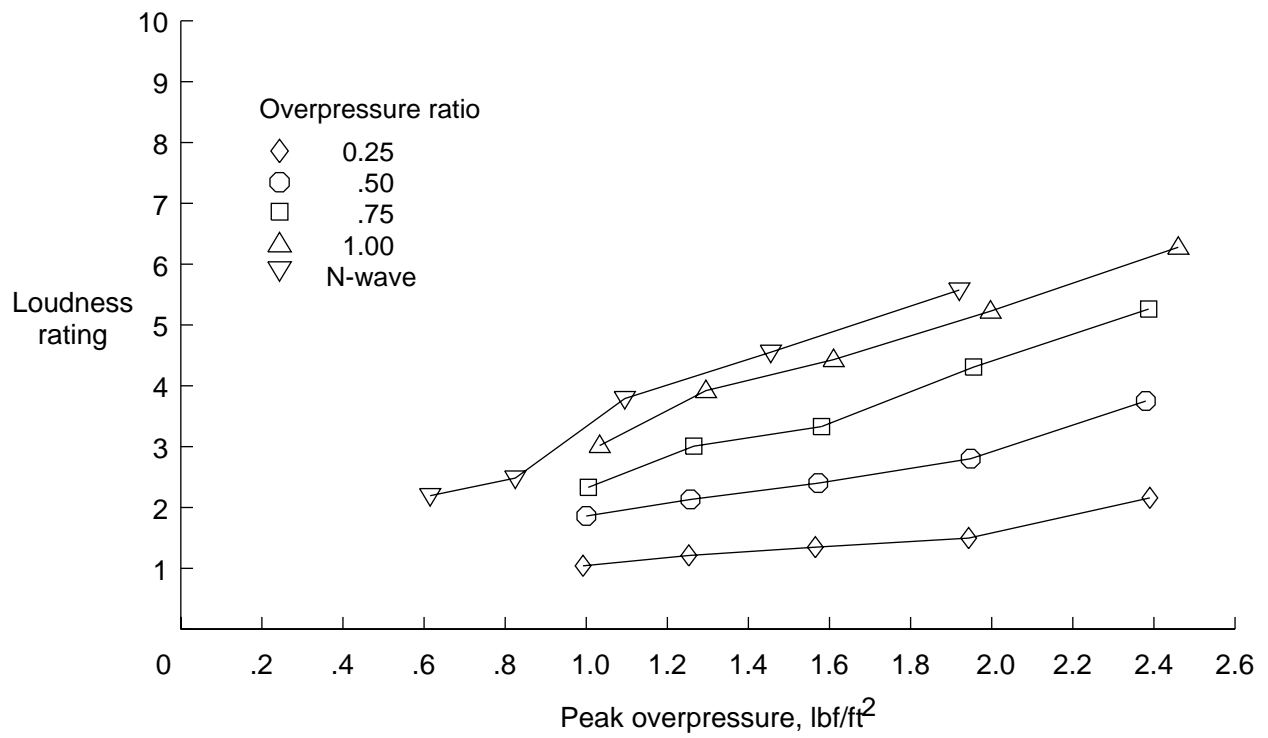

(c) $\tau_1 = 4$ msec.

Figure 6. Concluded.

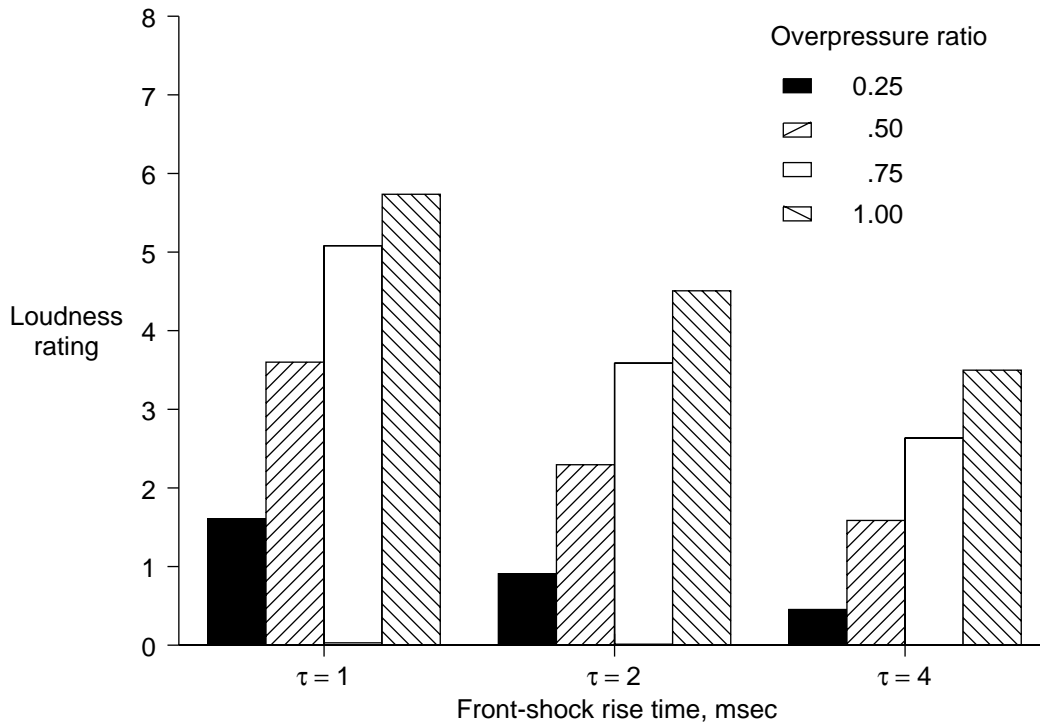

(a) $\Delta P_{\max} = 1.0 \text{ lbf/ft}^2$.

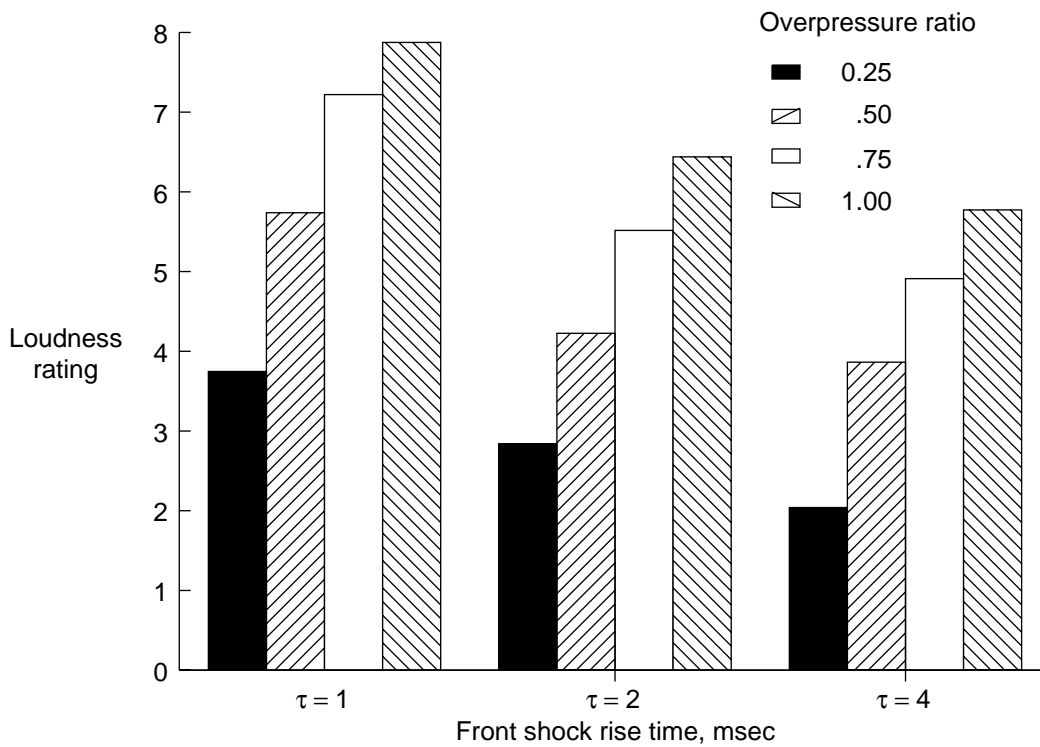

(b) $\Delta P_{\max} = 2.0 \text{ lbf/ft}^2$.

Figure 7. Subjective loudness effects of front-shock rise time and overpressure ratio for peak overpressures of 1.0 and 2.0 lbf/ft².

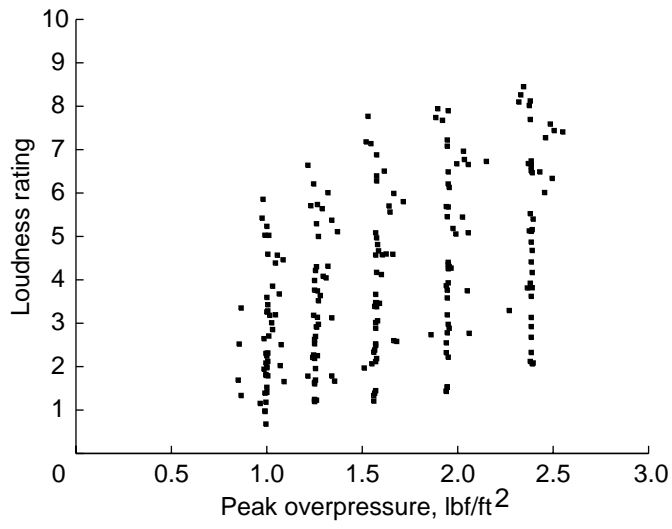

(a) ΔP_{\max} , lbf/ft².

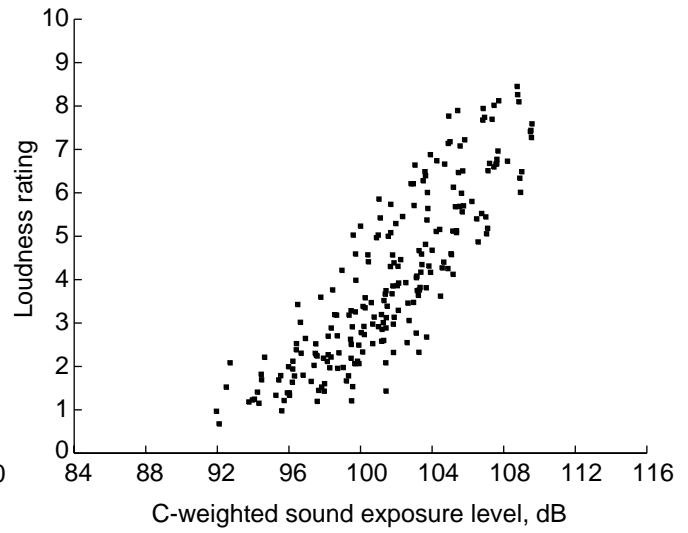

(b) L_{CE} , dB.

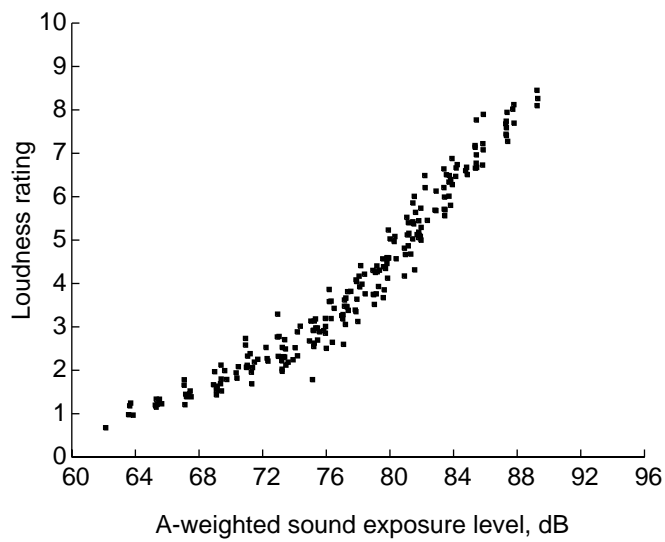

(c) L_{AE} , dB.

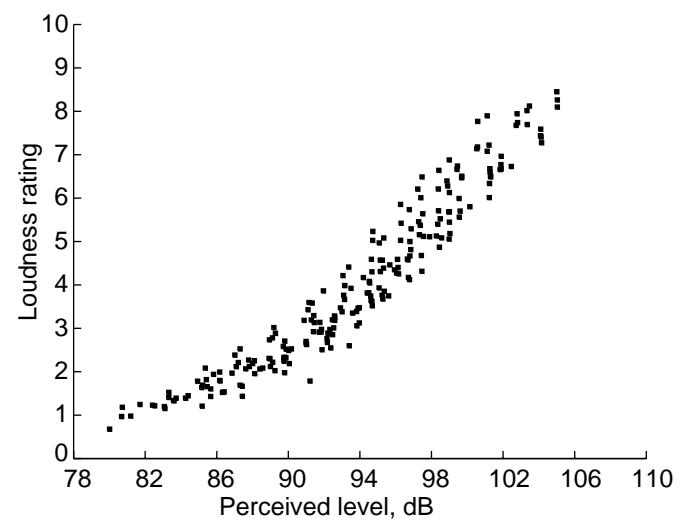

(d) PL , dB.

Figure 8. Scatter diagrams for metrics ΔP_{\max} , L_{CE} , L_{AE} , and PL .

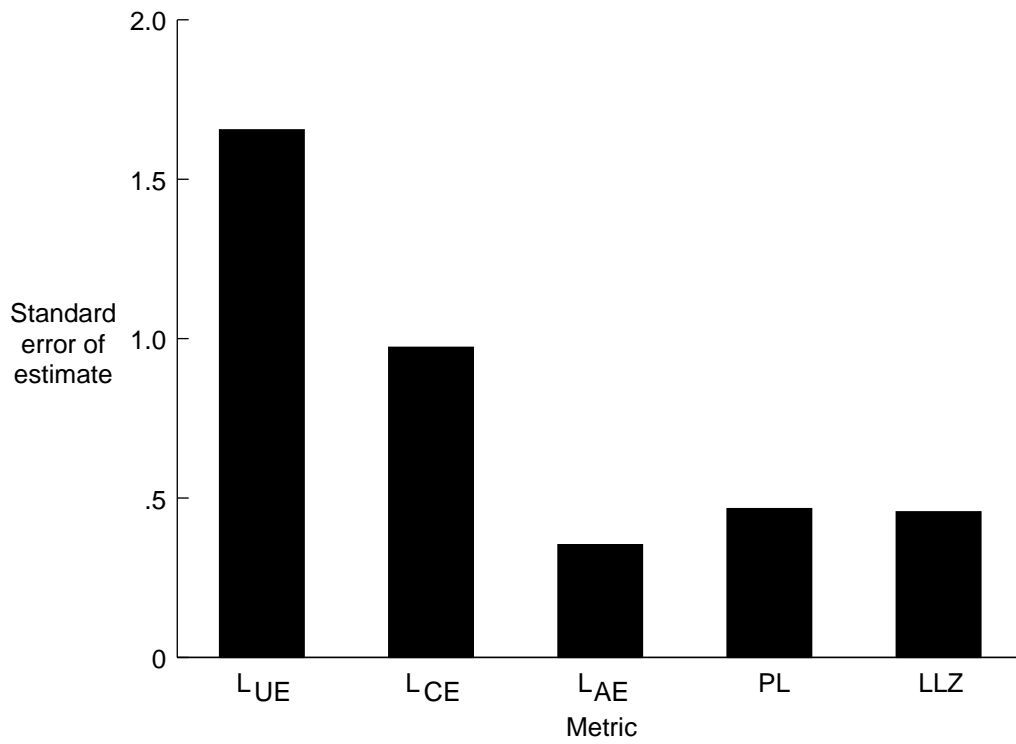

Figure 9. Standard errors of estimate (prediction error) for metrics L_{UE} , L_{CE} , L_{AE} , PL , and LLZ .

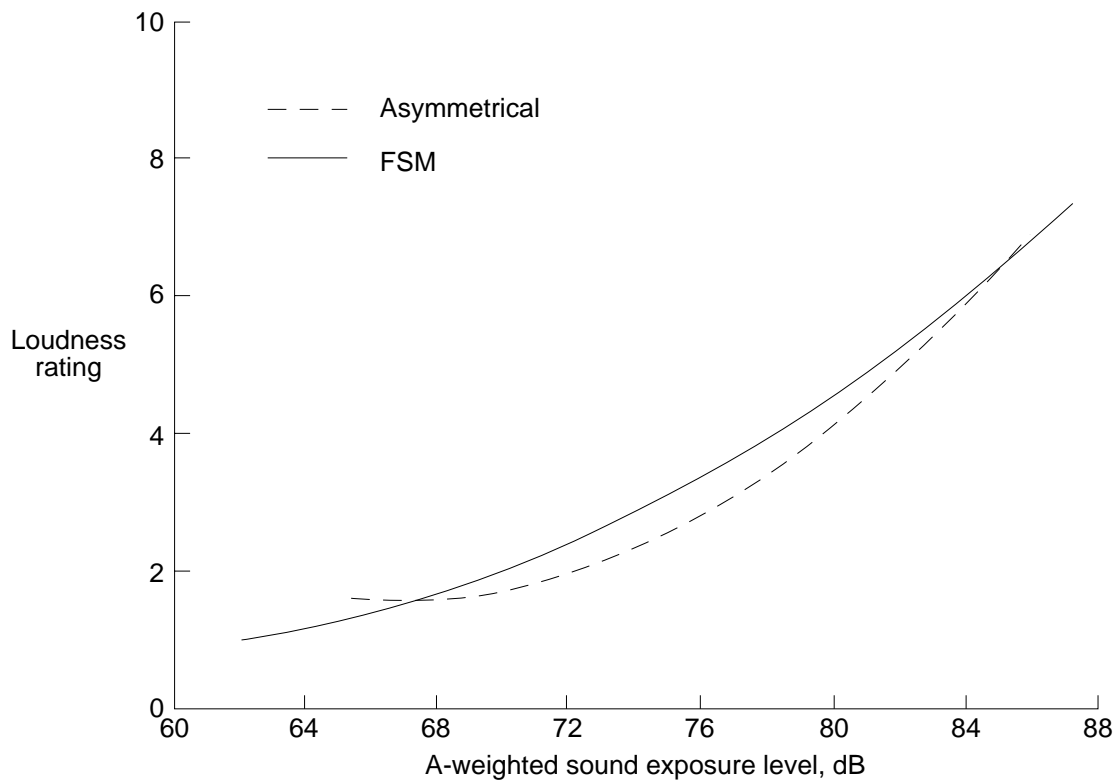

Figure 10. The FSM versus asymmetric boom loudness comparison.

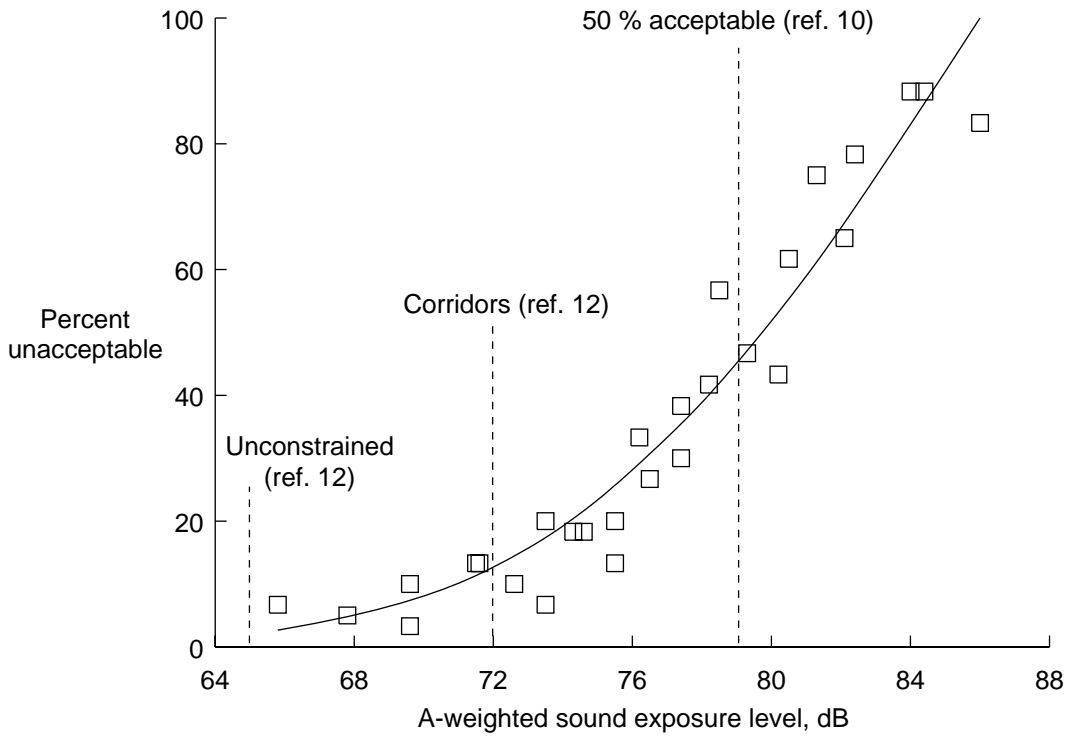

Figure 11. Percent of unacceptable ratings versus L_{AE} with comparisons to criteria derived from references 10 and 12.

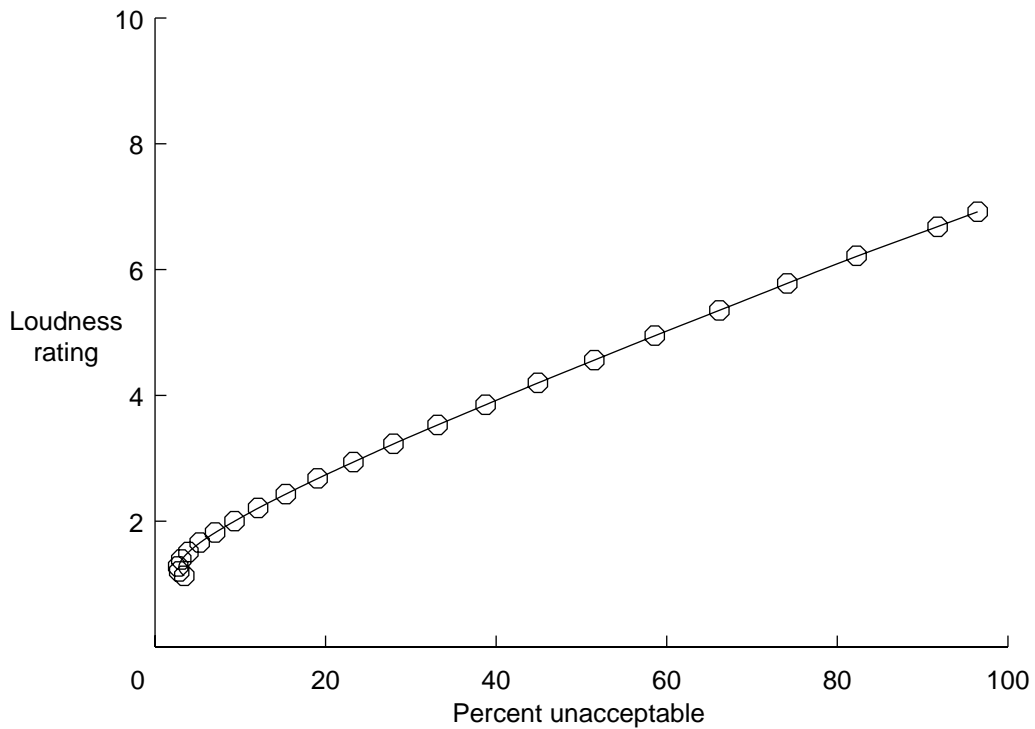

Figure 12. Relationship between numerical category scale ratings and percent of unacceptable ratings based upon data of present study.

